

***BJ-10sx***

**USER  
MANUAL**

**Canon**

---

# Contents

---

<b>Chapter 1</b>	<b><a href="#">Introduction</a></b> .....	<b>1</b>
	<a href="#">Features and Benefits</a> .....	1
	<a href="#">Using This Manual</a> .....	3
	<a href="#">Customer Support</a> .....	5
<b>Chapter 2</b>	<b><a href="#">Setting Up the Printer</a></b> .....	<b>7</b>
	<a href="#">Unpacking the Printer</a> .....	7
	<a href="#">Examining the Printer</a> .....	8
	<a href="#">Assembling the Printer</a> .....	12
<b>Chapter 3</b>	<b><a href="#">Using the Printer</a></b> .....	<b>23</b>
	<a href="#">Choosing a Location for Your Printer</a> .....	23
	<a href="#">Loading Paper</a> .....	24
	<a href="#">Using the Printer On a Daily Basis</a> .....	31
	<a href="#">Traveling With the Printer</a> .....	32
<b>Chapter 4</b>	<b><a href="#">Using the Operator Panel</a></b> .....	<b>35</b>
	<a href="#">Turning On the Printer</a> .....	35
	<a href="#">Pausing a Print Operation</a> .....	36
	<a href="#">Feeding Paper</a> .....	36
	<a href="#">Selecting a Print Mode</a> .....	37
	<a href="#">Changing the Character Pitch</a> .....	37
	<a href="#">Changing the Font Style</a> .....	38
	<a href="#">Printing the Test Prints</a> .....	41
<b>Chapter 5</b>	<b><a href="#">Using the Printer With Software</a></b> .....	<b>47</b>
	<a href="#">Setting Up Windows 3.1 for Your Printer</a> .....	47
	<a href="#">Setting Up Other Software Applications</a> .....	53
	<a href="#">Software and Printer Compatibility</a> .....	55
<b>Chapter 6</b>	<b><a href="#">Maintaining the Printer</a></b> .....	<b>57</b>
	<a href="#">Cautions</a> .....	57
	<a href="#">Cleaning the Printer</a> .....	57
	<a href="#">Replacing the Ink Cartridge</a> .....	59
	<a href="#">Storing the Printer</a> .....	65
<b>Chapter 7</b>	<b><a href="#">Troubleshooting</a></b> .....	<b>67</b>
	<a href="#">Checking the Indicator Lights</a> .....	67
	<a href="#">Printing the Self Test</a> .....	69
	<a href="#">Print Quality Problems</a> .....	70
	<a href="#">Paper Loading Problems</a> .....	70
	<a href="#">Printing Problems</a> .....	71
	<a href="#">Clearing Paper Jams</a> .....	72

	<a href="#">Cleaning the Print Head .....</a>	<a href="#">75</a>
<b>Chapter 8</b>	<a href="#">Customizing the Printer .....</a>	<a href="#">77</a>
	<a href="#">Factory Default Settings .....</a>	<a href="#">77</a>
	<a href="#">DIP Switch Settings .....</a>	<a href="#">78</a>
	<a href="#">BJ-10e Mode .....</a>	<a href="#">80</a>
	<a href="#">Epson LQ Mode .....</a>	<a href="#">82</a>
<b>Chapter 9</b>	<a href="#">Installing and Using Options .....</a>	<a href="#">85</a>
	<a href="#">Sheet Feeder .....</a>	<a href="#">85</a>
	<a href="#">Battery Pack .....</a>	<a href="#">88</a>
<b>Appendix A</b>	<a href="#">Printer Specifications .....</a>	<a href="#">95</a>
	<a href="#">Options Specifications .....</a>	<a href="#">100</a>
<b>Appendix B</b>	<a href="#">Interface Specifications .....</a>	<a href="#">103</a>
<b>Appendix C</b>	<a href="#">Printer Mode Command Summaries and Character Sets .....</a>	<a href="#">109</a>
	<a href="#">BJ-10e Command Summary .....</a>	<a href="#">109</a>
	<a href="#">BJ-10e Character Sets .....</a>	<a href="#">116</a>
	<a href="#">Epson LQ Command Summary .....</a>	<a href="#">120</a>
	<a href="#">Epson LQ Character Sets .....</a>	<a href="#">125</a>
	<a href="#">Glossary .....</a>	<a href="#">129</a>
	<a href="#">Index .....</a>	<a href="#">139</a>

# Chapter 1

## Introduction

---

Congratulations on your purchase of the Canon Bubble Jet Printer BJ-10sx. It offers exceptional print quality and trouble-free operation with the convenience of compact size, low cost, and portability. We appreciate your choosing this portable printer to meet your printer needs.

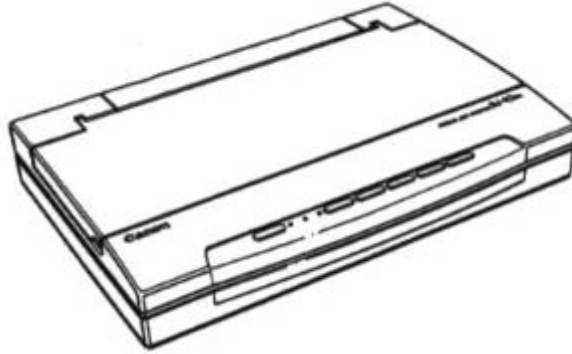

This chapter introduces you to features of your new printer and describes how to use this User's Manual.

### ***Features and Benefits***

The Bubble Jet Printer BJ-10sx produces high-quality printing by incorporating many useful features.



**Feature**

**Benefit**

Compact portable design

The printer's compact design (3.7lb/1.7kg) allows it to easily fit into a briefcase. With the optional battery pack, you can print documents without AC power, a fully charged battery can print up to 40 pages.

Convenient paper handling

You can print on paper, envelopes, or transparencies. An optional sheet feeder is available for automatically feeding stacks of paper

Software compatibility

Two resident printer control modes allow the printer to emulate other printers: BJ-10e mode provides emulation of the Canon Bubble Jet printers as well as the IBM proprinter X24E, an Epson LQ mode provides emulation of the Epson LQ-510 printer. This means your printer is compatible with a wide variety of software applications including those that support the Proprinter X24E and LQ-510, as well as any of the other Canon Bubble Jet printers (BJ-10e, BJ-10ex, BJ-20, and BJ-130e).

Excellent print quality

The high-performance print head of the ink cartridge offers 360 by 360 dots per inch (dpi) for high resolution graphics. This gives you the output quality of a laser printer and enables you to create attractive presentations while on the road.

High-quality ink

The ink cartridge contains a high-quality ink that is not easily affected by light. It dries very quickly so it is resistant to smudges. Printed output does not fade as the cartridge runs out of ink; the printer maintains the same print quality regardless of how many characters have been printed with the cartridge.

Simple maintenance

The replaceable ink cartridge contains both the ink and the print head for the printer. When it runs out of ink, you simply replace it. Each cartridge typically prints 400 to 500 pages (700,000 characters) in high quality (HQ) mode, and 800 to 1000 pages (1,400,000 characters) in economy mode.

Quiet printing

The printer uses a non-impact printing method that is very quiet.

# Using this Manual

This section describes the contents and conventions of this manual.

## Contents

This manual includes all the information you need to set up and operate your printer in several easy-to-read chapters.

### **Chapter 1, Introduction**

Introduces you to the features of the printer, and describes how this manual is organized.

### **Chapter 2, Setting up the Printer**

Describes the printer's components, and how to unpack and assemble it.

### **Chapter 3, Using the Printer**

Describes how to select a location for your printer, select paper and load it in the printer, and print on envelopes, transparencies, and thick paper. It also includes helpful hints for using the printer on a daily basis and traveling with the printer.

### **Chapter 4, Using the Operator Panel**

Explains how to control your printer using the buttons on the operator panel.

### **Chapter 5, Using the Printer With Software**

Describes how to install a printer driver and select a printer control mode.

### **Chapter 6, Maintaining the Printer**

Describes how to clean the printer, replace the ink cartridge, and store the printer.

### **Chapter 7, Troubleshooting**

Provides procedures to help you solve problems that may occur when using the printer.

### **Chapter 8, Customizing the Printer**

Explains how you can customize the factory default settings and select the printer control mode of the printer by changing the DIP switches.



## Chapter 9, Installing and Using Options

Describes how to install the options available for the Canon Bubble Jet Printer BJ-10sx.

The appendices include printer specifications, interface specifications, and summary tables of the BJ-10e mode and Epson LQ mode printer commands and characters sets.

At the back of this manual, you'll find a Quick Reference card. To detach the card, cut along the dotted line at the left side of the card; then fold the card down the center. Take this Quick Reference with you when you travel with the printer.

The Canon Bubble Jet Printer BJ-10sx Programmer's Manual is available for software designers, advanced programmers, and users interested in using a programming language to send commands to the printer. To obtain a copy of this manual, call the Canon Computer Systems Technical Support help desk at 1-800-423-2366.

## Conventions

This User's Manual uses the following conventions to alert you to the information that will help you to operate the printer correctly and safely:

---



**NOTE:** Notes provide advice or suggestions regarding the use of the printer.

---



**CAUTION:** Cautions alert you to operations that could cause damage to your printer or other components.

---

Distinctive typefaces identify the printer buttons you press, the lights on the operator panel, and any commands you enter at your computer. For example, the buttons you press appear in this typeface: **POWER**. The lights you see appear in this typeface: **ERROR**. When you type something on your computer, it appears in this typeface: DIR /P.

◀ BACK

NEXT ▶

▶ BACK TO START

# *Customer Support*

Canon provides customer support and service for all Canon printer products. If you have any questions regarding the installation or use of your new printer, don't hesitate to call the Canon Computer Systems Technical Support help desk at 1-800-423-2366. Assistance is available Monday through Friday from 9 am to 9 pm, Eastern Standard Time (EST), except on holidays.

If you seem to have an operational problem, try to solve it by referring to the information in Chapter 7, Troubleshooting. If you cannot quickly resume normal operation, contact Canon's experienced support personnel at the help desk.

Canon also provides a bulletin board service (BBS). To find out the number for the BBS, call the help desk.

For CompuServe members, Canon provides the Canon Peripherals Forum. To access the Canon forum, type GO CANON at any CompuServe prompt.

Customer support for Canadian residents is available at 416-795-2083 from 9 am to 7 pm, EST (except holidays). In other countries, please contact your Canon dealer.





# Chapter 2

## Setting up the Printer

---

This chapter describes the steps you follow to unpack and set up your printer. It offers guidelines for using the printer, explains how to install the ink cartridge, and describes how to connect the AC adapter and the interface cable.

If you have already set up your printer using the Quick Start Guide included in the box, you may want to scan this chapter for the additional information that it supplies.

### ***Unpacking the Printer***

Carefully remove all items from the box.

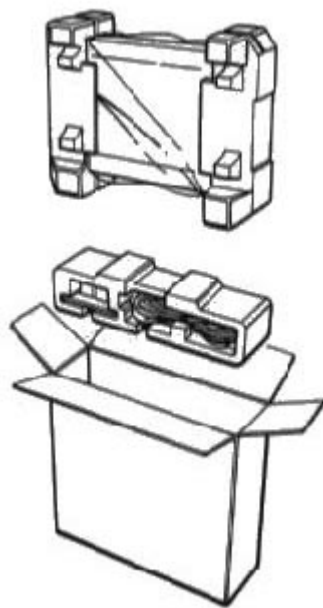

In addition to this User's Manual, you will find these items in the box:

- Canon Bubble Jet Printer BJ-10sx
- BC-01 ink cartridge
- AC adapter
- Quick Start Guide
- Product Warranty card
- Registration card

If your printer was damaged in shipping, or if any items are missing, notify your dealer immediately.

As you unpack the printer, save the carton and packing materials in case you want to ship or store the printer in the future. Remove all shipping tape and any styrofoam packing material used to protect the printer during shipping. Remove the protector cover the parallel port on the right side of the printer.

---



NOTE: Be sure to fill out your Registration card and send it to Canon Computer Systems, Inc.

---

## ***Examining the Printer***

Before setting up your printer, take this opportunity to become familiar with its components and understand their functions.



## *From the Front/Side*

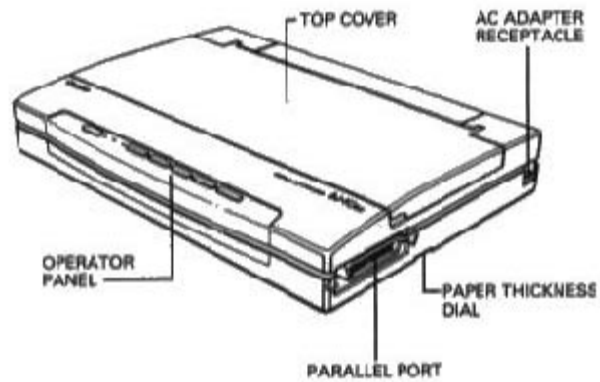

### **Operator Panel**

You can use the operator panel to control the printer and select basic printer operations. The various lights on the operator panel indicate the status of the printer and identify the print mode you've selected. See Chapter 4, *Using the Operator Panel*, for complete information on these buttons and lights.

### **Top cover**

The top cover is open when feeding paper or accessing the inside of the printer.

### **Parallel interface port**

The printer's interface cable connects to this port.

### **Paper thickness dial**

You set this dial according to the thickness of your paper. The setting you choose adjusts the distance between the print head and the paper. There are three settings: back toward the paper icon for normal-weight paper, in the center for printing graphics, and forward toward the envelope icon for thick paper or envelopes.

### **AC adapter receptacle**

The printer's AC adapter connects to this receptacle.



## *From the Back*

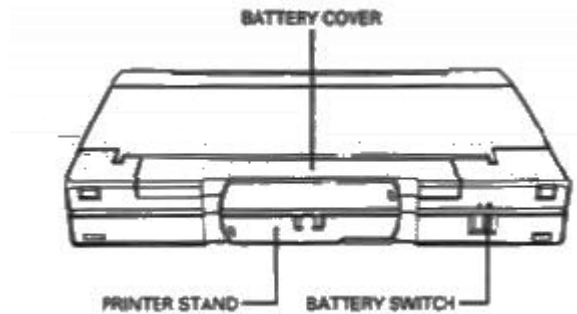

### **Printer stand**

The printer stand is used when printing envelopes, transparencies, or thick paper.

### **Battery cover**

This cover protects the optional battery pack.

### **Battery switch**

This switch turns on the optional battery pack (if it is installed).



## *Inside the Printer*

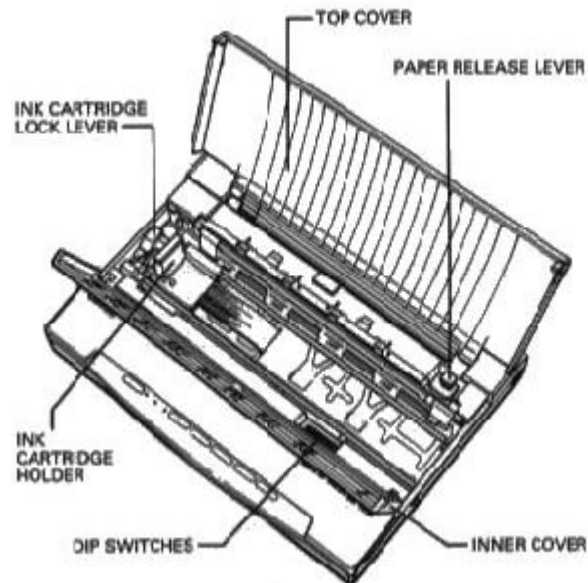

### **Inner cover**

This cover provides access to the inside of the printer when you're installing the ink cartridge or changing the DIP switches.

### **Ink cartridge holder**

You install the ink cartridge on this yellow holder as described later in this chapter.

### **Ink cartridge lock lever**

This lock lever secures the ink cartridge.

### **Paper release lever**

This lever releases the loaded sheet of paper. You lift this lever to clear a paper jam. Leave the lever in the down position when you are printing.

◀ BACK

NEXT ▶

▶ BACK TO START

### DIP switches

These switches define the printer's settings. For information about changing the factory default settings, see Chapter 8, Customizing the Printer.

## Assembling the Printer

Now that you are familiar with the components of your printer, you are ready to set up the printer and connect to your computer. The first step is to install the ink cartridge.

### Installing the Ink Cartridge

The ink cartridge you use with the printer is BC-01. Each ink cartridge contains enough ink to print about 400 to 500 pages (700,000 characters) in high quality mode (HQ) mode, and 800 to 1000 pages (1,400,000 characters) in economy mode. The actual amount varies according to the print density of the page. If you print a lot of graphics, you may need to change the cartridge more often.

---



**CAUTION:** Canon makes two ink cartridges that would fit the printer; the BC-01 is designed specifically for the Bubble Jet Printer BJ-10sx. Therefore, use only the BC-01 cartridge with this printer.

---

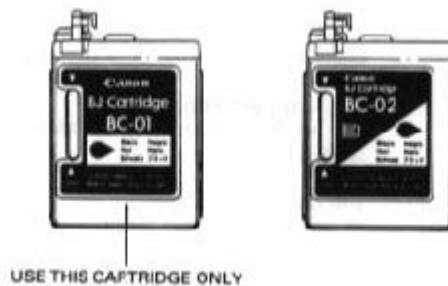

To avoid spilling ink, follow these precautions:

- Do not touch the print head on the ink cartridge or the sharp edges around it.
- Do not hold the ink cartridge, or place it on a surface, with the print head facing down.
- Do not attempt to disassemble the cartridge.
- Do not vigorously shake the ink cartridge while handling it.



---

**CAUTION:** Keep the ink cartridge out of the reach of children; the ink contains isopropyl alcohol 67-63-0.

---

To install the ink cartridge, follow these steps:

1. Grasp the recessed tab on each side of the top cover, and lift the cover toward the back of the printer.

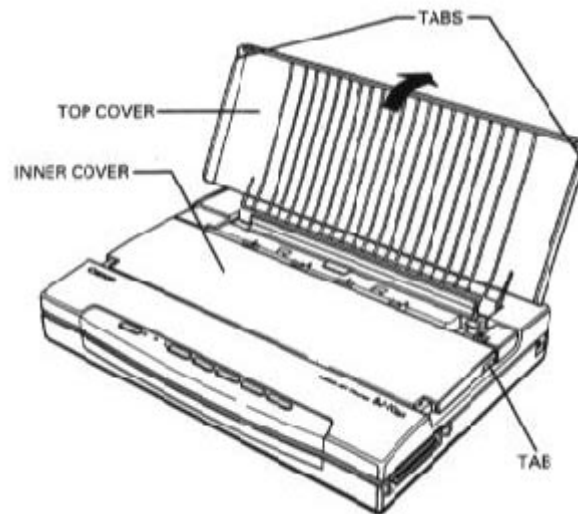

2. Grasp the recessed tab on each side of the inner cover, and lift the cover toward the front of the printer.

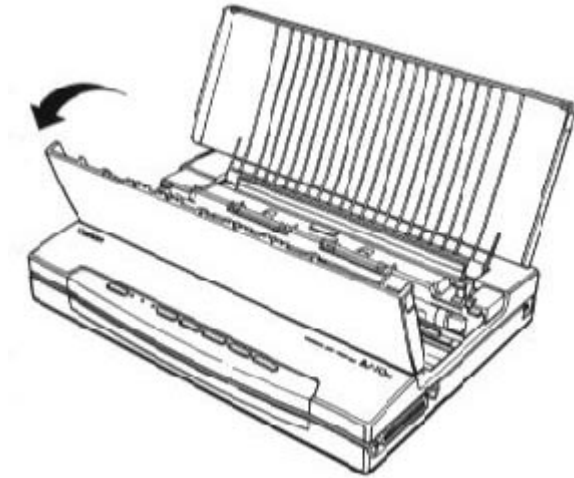

3. Take the ink cartridge out of its protective packaging.





4. Snap off the orange cap from the print head and then remove the orange tape.

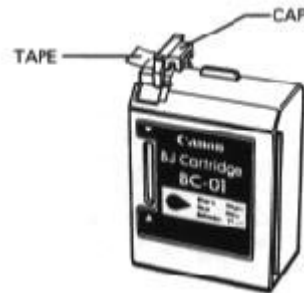

5. Locate the ink cartridge holder on the left side of the printer.

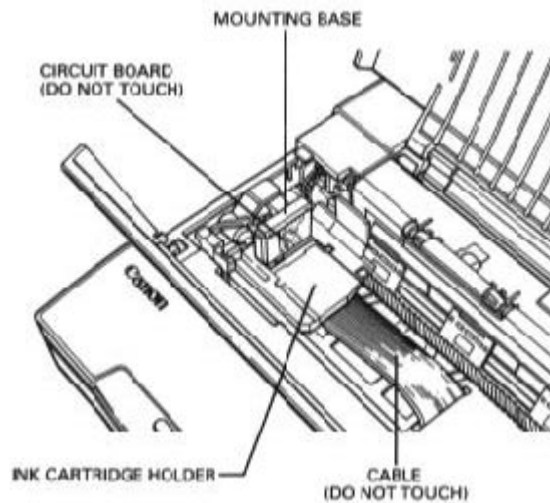

**CAUTION:** Avoid touching the yellow mounting base on which you place the cartridge -- especially the circuit board on the side of the mounting base and the film cable that extends from the carriage holder.

6. Lift the green lock lever on the cartridge holder.

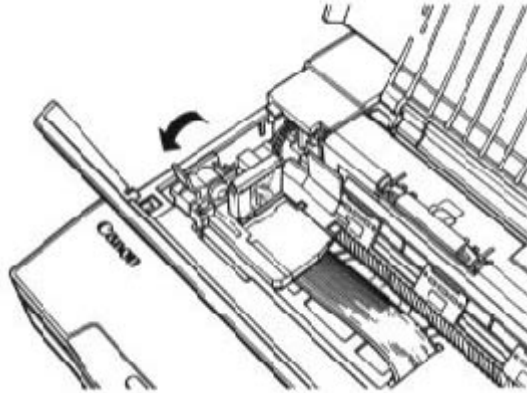

7. Fit the ink cartridge over the yellow mounting base with the print head facing the back of the printer.

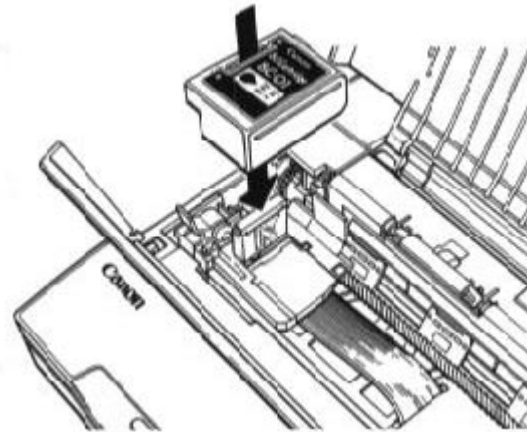

8. Push the lock lever back until it snaps into place. This secures the ink cartridge so it makes contact with the circuit board on the cartridge holder.

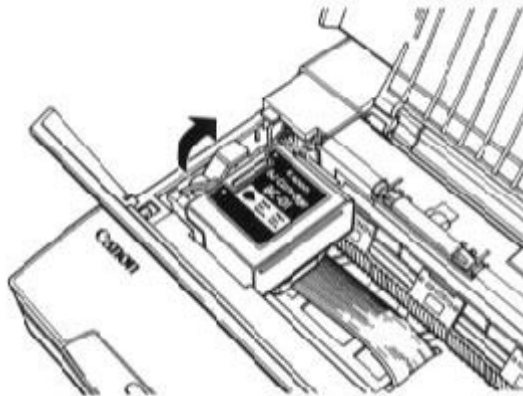

**CAUTION:** Do not move the ink cartridge after installing it. Moving the ink cartridge to the right and leaving it there may uncaps the print head and cause it to dry out.

9. Close the inner cover. Press on each side until it snaps into the closed position.
10. Lower the top cover and press on each side to close it securely.

Whenever you turn off the printer, the ink cartridge moves to its home position on the left and caps itself to keep from drying out. If you unplug the printer while it is printing, or if you move the ink cartridge from the home position, the cartridge will not be capped and it may dry out.

## ***Attaching the AC adapter***



**CAUTION:** Use only the AC adapter that came with the printer. Use of any other adapter may damage the printer.

1. Plug the connector end of the AC adapter into the AC adapter receptacle on the right side of the printer.

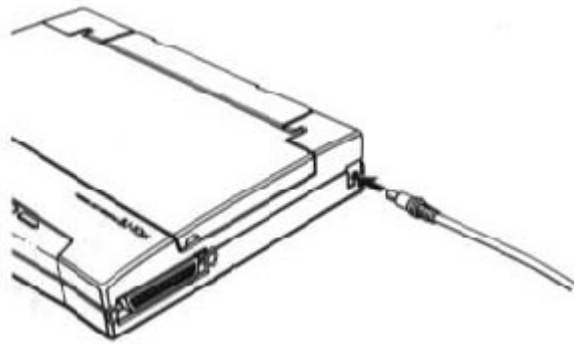

2. Insert the AC adapter into the wall outlet.



**CAUTION:**

- If you smell a peculiar odor, or see smoke, unplug the AC adapter immediately.
- Do not place anything in front of your wall outlet that may obstruct your access to it or put pressure on the AC adapter.
- Always plug the AC adapter into the printer before you plug it into an electrical outlet.
- Always unplug the AC adapter from the wall outlet before you

If you plan to use the printer while traveling, check the voltage requirements of countries you will be visiting. If necessary, obtain an appropriate AC adapter from your Canon dealer. You can also call the Canon help desk at 1-800-423-2366.

Electrical current flows into the AC adapter when it is plugged into a wall outlet. If you will not be using the printer for some time, unplug the AC adapter from the wall outlet and from the printer.

## ***Connecting the Printer to Your Computer***

Your printer has an 8-bit, parallel interface port. You can obtain a Centronics compatible, parallel interface cable from your dealer. Ask your dealer for assistance if you need help selecting the right cable.

1. Make sure both the printer and the computer are turned off.
2. If you have not already done so, remove the cap from the parallel port.
3. Align the cable connector with the printer's parallel port so the shapes match. Gently press the cable connector into the printer's parallel port.

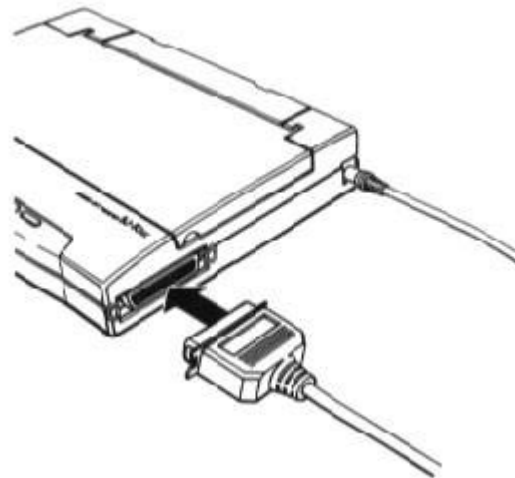

4. Secure the cable connector by snapping the two wire clips (located on the printer) into the cable connector.
5. Connect the other end of the interface cable to the parallel port on your computer.

## ***Turning the Printer On and Off***

To turn on the printer, press the **POWER** button on the operator panel until the printer sounds a beep. The **POWER** light comes on, and the printer makes several sounds as it gets ready to print.

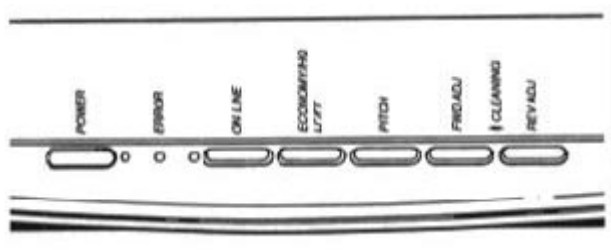

---

**CAUTION:** Never unplug the AC adapter when the power is turned on. This may cause the print head to remain where it is without returning to the home position. Once in the home position, the print head is capped, which protects it from damage or drying out.



---

To turn off the printer, press the **POWER** button again. Always turn off the printer when you will not be using it.

---

**NOTE:** After turning off the printer, always wait at least four seconds before turning it back on.

---

◀ BACK

NEXT ▶

▶ BACK TO START



# Chapter 3

## Using the Printer

---

This chapter presents the guidelines for locating your printer, describes how to load paper, envelopes, transparencies, and thick paper in the printer, and provides helpful hints for using the printer on a daily basis and traveling with the printer.

### *Choosing a Location for Your Printer*

Whether at home, in the office, or traveling, you need to find a comfortable and convenient location for the printer. Follow the guidelines in this section to make sure the location is right for your printer.



- Place the printer in a cool, dry, clean, well ventilated area. Avoid placing it in direct sunlight.
- Set the printer on a sturdy, level surface. This is especially important when traveling with the printer.
- Use the printer only where the temperature is stable and set for human comfort.

◀ BACK

NEXT ▶

▲ BACK TO START



- Make sure the printer's location is near an electrical wall outlet that accepts a three-prong, grounded plug when you are using the AC adapter.

---

**CAUTION:** Use only the AC adapter that came with your printer. Attempting to use any other adapter may damage the printer.



- Keep the printer and your computer away from potential source of electromagnetic interference, such as loud speakers or the base units of cordless telephones.
- Make sure there is enough room around the printer for handling the paper.
- Keep the printer clear from objects that may block the paper from exiting.

## ***Loading Paper***

To assure the best performance of your printer, you want to select the best paper and load it correctly.

Single sheets of paper are loaded from the top of the printer with the top cover open.



Envelopes, transparencies, and thick paper are loaded from the bottom of the printer with the printer resting on the printer stand.

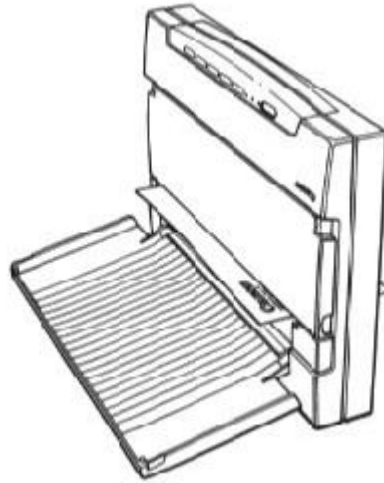

To load multiple sheets of paper, you must install the optional sheet feeder. See Chapter 9, *Installing and Using Options*, for details.

## ***Selecting Paper***

Your printer produces letter-quality output on most plain bond papers, including cotton bond papers and photocopying papers. This printer does not require special ink-jet papers.

Use cut-sheet paper only. Do not use multiple-part forms.

The printer prints better on some paper than others, and the quality of paper varies across the United States. Before purchasing a large amount of paper, buy a small amount and test it to see if it meets your printing requirements.

---



**NOTE:** Attempting to print on damp, curled, wrinkled, or torn paper can cause paper jams and poor print quality.

---

◀ BACK

NEXT ▶

▲ BACK TO START

You can print on single sheets of plain papers that match these specifications:

<i>Size</i>	7.2 by 10.1 inches to 8.5 by 14.0 inches (182 by 257 mm to 216 by 356 mm)
<i>Thickness</i>	Less than 0.008 inches (0.2 mm)
<i>Weight</i>	17 to 24 lbs (64 to 90 g/m <sup>2</sup> ) -- loaded from top cover 17 to 28 lbs (64 to 105 g/m <sup>2</sup> ) -- loaded from bottom slot

## ***Printing On Paper***

When you are ready to print on plain paper, follow these steps:

1. Make sure the printer is turned off, and close the top cover if it is open.
2. Set the printer on its back and adjust the paper thickness dial. Set the dial to the top position (paper icon) if you will be printing text. Set the dial to the center position (no icon) if you will be printing graphics.

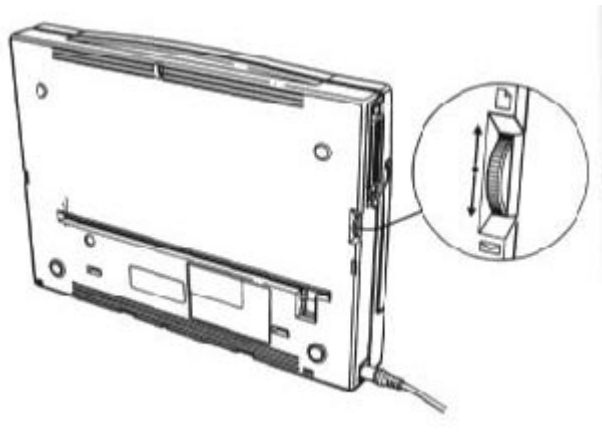

3. Set the printer on a level surface and open the top cover.

4. Press the POWER button to turn on the printer. The ERROR light comes on because there is no paper in the printer.
5. Make sure the paper release lever on the right side of the printer is pushed down. Paper will not feed correctly if the lever is up

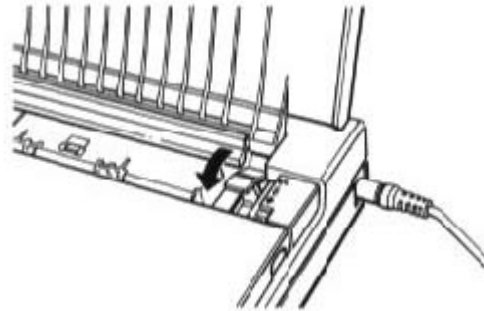

6. Insert a single sheet of paper into the printer. Align the paper with the paper size indicator on the left side of the top cover.



1. Make sure you insert the paper so that the side on which you want to print is facing away from you (toward the top cover). If you are using a preprinted stock, such as a sheet of letterhead, insert the top of the paper into the printer first.
2. Press the **LF/FF** button. The printer automatically positions the paper so it is ready for printing.
3. Press **ON LINE** and start your print operation.

## ***Selecting Envelopes, Transparencies, or Thick Paper***

Use commercial, number 10 envelopes, which are 9.5 by 4.125 inches (241 by 104 mm).

---



**CAUTION:** Some envelopes are not recommended since they may cause jams or smears, or may damage your printer. Do not use the following types of envelopes:

- Envelopes with windows, metal clasps, holes, perforations, cutouts, double flaps, or peel-off sealing strips.
  - Envelopes that are specially coated or deeply embossed.
  - Envelopes with letters enclosed
- 

Use transparencies that are intended for use with ink jet printers only. For best results, use Canon's BJ transparency film #Q07-0001-M1. You can also use CG3480 transparency film from 3M.

---



**NOTE:**

- Always feed transparencies from the bottom slot on the printer.
  - Use transparencies only in a normal operating environment. High temperatures may damage a transparency.
- 

You can print on heavier-weight paper (up to 28 lbs or 105 g/m<sup>2</sup>).

## ***Printing On Envelopes, Transparencies, or Thick Paper***

You must load envelopes, transparencies, and thick paper from the bottom slot of the printer.

To load envelopes, transparencies, or thick paper, follow these steps. (The illustrations show how to load an envelope; the steps are exactly the same for transparencies or thick paper.)

1. Make sure the printer is turned off and the top cover is closed.
2. Grasp the front of the printer with one hand and position the printer stand with your other hand.



3. Turn the printer stand so it is perpendicular to the back of the printer and set the printer on it's back.

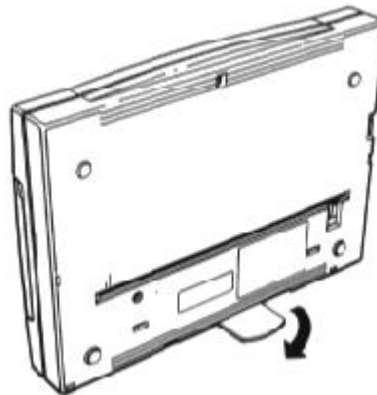

4. Open the top cover.
5. Press the **POWER** button to turn on the printer. The **ERROR** light comes on because there is no paper in the printer.
6. Set the paper thickness dial to the bottom position (envelope icon).

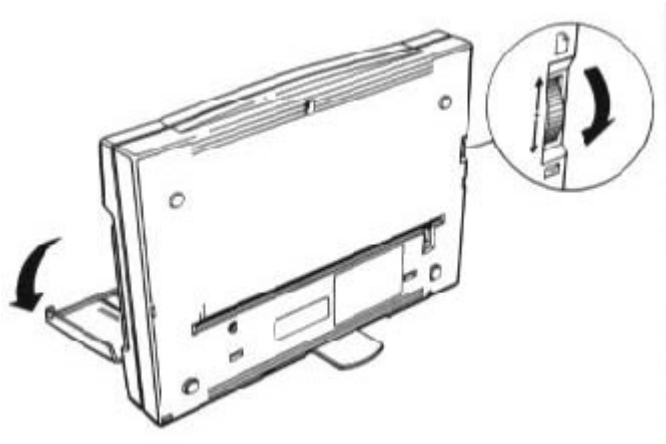

7. Align the envelope, transparency, or paper with the paper size indicator on the left side of the bottom slot.

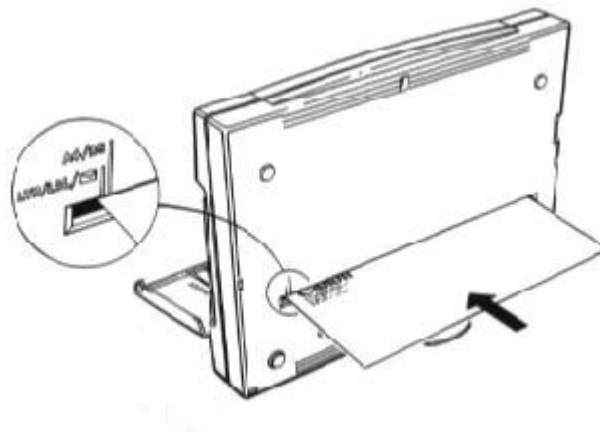



8. Make sure you insert the top of the envelope, transparency, or paper first. Make sure the side on which you want to print is facing up.

---

**NOTE:** The top of the transparency is where the transparency and its backing are attached. Always insert a transparency with the transparency up and the backing down.

---

9. Press the **LF/FF** button to advance the envelope, transparency, or paper one line at a time. Press **FWD ADJ** or **REV ADJ** for fine adjustment. (See Chapter 4, Using the Operator Panel, for details.)
10. When the envelope, transparency, or paper is positioned correctly, press **ON LINE** and start your print operation.



---

**NOTE:** After printing on envelopes, transparencies, or thick paper, set the paper thickness dial on the right side of the printer back to the top position (paper icon) before printing on normal-weight paper again.

---

## ***Using the Printer On a Daily Basis***

Follow the guidelines presented here to obtain the optimum performance from your Bubble Jet Printer BJ-10sx.

- Canon makes numerous ink cartridges; the BC-01 is designed specifically for the Bubble Jet Printer BJ-10sx. Therefore, use only the BC-01 cartridge with this printer.
- After installing a new ink cartridge, always perform the print head cleaning procedure.
- Never touch the print head on the ink cartridge or attempt to clean it with a cloth.
- Keep the inner cover closed when printing.



- For best printing quality, use a bond paper with a cotton fiber content (for example, 25% cotton bond paper).
- Use only the AC adapter that comes with the printer.
- Always turn off the printer before unplugging the AC adapter -- this allows the print head to return to the home position and prevents the print head from drying out.
- If you have installed a battery pack, keep the battery switch turned off when you are not using battery power.
- Keep the inside of the printer clean and dust free; use canned air to clean the inside of the printer.
- Perform the print head cleaning procedure if your output is not crisp and clear.
- Keep the ink cartridge out of the reach of children; the ink contains isopropyl alcohol 67-63-0.

## ***Traveling With the Printer***

Before transporting the printer, follow these steps to protect the print mechanism:

1. Turn off the power. This secures the print head in the home position.
2. Remove any paper from the printer.
3. Disconnect the interface cable and the AC adapter.
4. If an optional battery pack is installed, turn off the battery switch.
5. If the optional sheet feeder is installed, remove it.
6. Close the covers if necessary.



---

**NOTE:** The printer is designed so that you can transport it with the ink cartridge installed. Therefore, do not remove the ink cartridge. An opened ink cartridge that is not installed in the printer may leak, and the print head may dry out.



- 
7. Place the printer and any accessories in a suitable carrying case.



Follow these additional guidelines:

- If you are traveling to another country, make sure the AC adapter matches the power requirements of that country.
- When traveling with the printer, always pack it with your carry-on items. Do not ship the printer in a suitcase due to baggage handling techniques.



---

**NOTE:** You can take the printer through airport X-ray security checks.

---

◀ BACK

NEXT ▶

▶ BACK TO START

- When the battery pack is low, you can attach the AC adapter to continue printing. You can also use the remaining battery power for limited printing by pressing **ON LINE**.
- You can travel with additional battery packs that are fully charged.
- Recharge the battery pack only when the printer indicates a low battery error. Charging the battery before it is fully discharged reduces the battery capacity. (See Chapter 9, Installing and Using Options, for details on the battery pack.)
- Avoid leaving the printer in a closed automobile where it may be exposed to extreme changes in temperature or humidity.
- After installing an ink cartridge, always leave it in the printer.



# Chapter 4

## Using the Operator Panel

---

You can control basic printer operations through the operator panel. The indicator lights reflect the current status and modes of the printer.

Most software applications, such as word processing programs, spreadsheets, and databases, automatically handle the printer control operations. For example, your word processing program tells the printer what typeface to use and when to perform a line feed or form feed.

If, for some reason, your application program does not perform these basic functions, you can control them using the operator panel. You can also select printer-specific functions, such as the print mode, and you can start the self tests.



The following sections of this chapter describe how you use these buttons to select printer functions.

### *Turning On the Printer*

Press and hold the **POWER** button to turn on the printer. The **POWER** light comes on. When the printer is ready to print, the **ON LINE** light comes on.



## ***Pausing a Print Operation***

When the **ON LINE** light is on, the printer is on-line and ready to receive data from your computer. At this time, you can send print data from your computer to the printer.

If you want to pause a print operation, press the **ON LINE** button to set the printer off-line. The **ON LINE** light goes off and the printer stops. To resume printing, press the **ON LINE** button.

## ***Feeding Paper***

When the printer is off-line, you can use the **LF/FF** button to advance the paper in the printer. You can perform a form feed or a line feed, or you can eject a sheet of paper.

### **Form feeding**

Insert a sheet of paper into the printer, make sure the printer is off-line, and press the **LF/FF** button to load the sheet of paper to its top of form. Set the printer back on-line to print. (If you are running a software application, you don't need to perform this step. The application tells the printer when to load paper.)

### **Line feeding**

When a sheet of paper is loaded and the printer is off-line, press the **LF/FF** button to advance the paper one line. Press the button repeatedly to advance as many lines as you want.

You can use the **FWD ADJ** or **REV ADJ** button to adjust the print position by 1/180 inch. Press the **FWD ADJ** button to move the paper forward by 1/180 inch, or press the **REV ADJ** button to move the paper backward by 1/180 inch.

### **Ejecting paper**

When you want to eject a sheet of paper, make sure the printer is off-line and press the **LF/FF** button for one second. The printer ejects the current sheet of paper.



## Selecting a Print Mode

Your printer includes two print modes: high quality (HQ) mode and economy mode. The default is HQ mode.

If you want to print a draft document, you can change the print mode to economy and save ink. In this mode, the printer uses less dots to form a character and uses less ink. In economy mode, your printed document will appear lighter.



**NOTE:** The print speed is 110 characters per second (cps) in both HQ and economy modes.

---

To select economy mode, follow these steps:

1. Make sure the printer is on-line.
2. Press the **ECONOMY/HQ** button. The printer sounds a long tone.

To return to HQ mode:

1. Make sure the printer is on-line.
2. Press the **ECONOMY/HQ** button. The printer sounds a short tone.

## Changing the Character Pitch

The pitch of a character determines how many characters are printed on a line. Pitch is measured in characters per inch (cpi) and adjusts the width of each character. A pitch of 17 cpi prints more characters on a line than a pitch of 12 cpi.

This text is 12 cpi.

This text is 17 cpi.

This text is proportionally spaced.

◀ BACK

NEXT ▶

▶ BACK TO START

You select a character pitch using the **PITCH** button. The available pitches depend on the printer control mode you are using, either BJ-10e mode or Epson LQ mode. (See Chapter 8, Customizing the Printer, for details on the printer control modes.) The default setting for both printer control modes is 10cpi.

To change the character pitch , follow these steps:

1. Press **ON LINE** to set the printer off-line.
2. Press the **PITCH** button to scroll through the available settings.

<b>Pressing the PITCH button</b>	<b>Selects BJ-10e mode</b>	<b>Epson LQ mode</b>
once	12 cpi	12 cpi
twice	17 cpi	15 cpi
three times	Proportional spacing	Proportional spacing
four times	Return to the default setting (10cpi)	Return to the default setting (10cpi)



**NOTE:** If you cannot remember the pitch you have selected turn off the printer, wait at least for seconds, and turn it back on. The printer restores the default setting of 10 cpi, and you can start over.

## Changing the Font Style

The font style determines the shape of a character. For example:

**This text is emphasized.**

**This text is double high.**

**This text is double wide.**

**This text shows a slashed zero, 0.**

# BJ-10e Mode Font Styles

In BJ-10e mode, the following font styles are available:

- Emphasized -- makes characters bold
- Double high -- doubles the height of characters
- Double wide -- doubles the width of characters
- Slashed zero -- adds a slash to a numeric zero

## Selecting a font style

To select a font style in BJ-10e mode, follow these steps:

1. Make sure the printer is on-line.
2. Simultaneously press the **ON LINE** and **PITCH** buttons. The printer sounds a long varied tone and the **ON LINE** indicator light blinks.
3. Press the **PITCH** button as follows.



<u>Press</u>	<u>Selects</u>
once	Emphasized
twice	Double high
three times	Double wide
four times	Slashed zero
five times	Unused
six times	Return to default settings
seven times	No change to current settings

The printer sounds a low tone each time you press the **PITCH** button, and it beeps twice after you press **PITCH** seven times.

---

**NOTE:** If you cannot remember the font style you have selected, press the **PITCH** button until the printer beeps twice. Now you can start over; press **PITCH** to select the desired font style.

---



4. Press the **LF/FF** button to confirm the change. The printer sounds a short tone (about 0.5 second).
5. Repeat steps 3 and 4 for each font style you wish to select. This allows you to combine several font styles.
6. Press **ON LINE** to set the printer on-line. The printer sounds a long varied tone

## ***Turning off a font style***

Follow these steps to turn off a font style:

1. Make sure the printer is on-line.
2. Simultaneously press the **ON LINE** and **PITCH** buttons. The printer sounds a varied tone and the **ON LINE** indicator line blinks.
3. Press the **PITCH** button the specified number of times for the font style you want to turn off.
4. Press the **LF/FF** button to turn off the font style. The printer sounds a long tone (about one second).
5. Repeat steps 3 and 4 for each font style you wish to turn off.
6. Press **ON LINE** to set the printer on-line.

## ***Epson LQ Mode Font Styles***

In Epson LQ mode, you can select between font styles of condensed and non-condensed. Selecting condensed mode changes the character pitch as follows:

10 cpi prints at 17 cpi

12 cpi prints at 20 cpi

If you have selected a character pitch of 15 cpi or proportional spacing, the printer ignores the condensed selection.



To select condensed or non-condensed printing in Epson LQ mode, follow these steps:

1. Make sure the printer is on-line.
2. Press the **PITCH** button to switch between condensed and non-condensed mode. Non-condensed is the default setting. The printer sounds a short tone for the condensed font style. The printer sounds a long tone for non-condensed mode.

## ***Printing the Test Prints***

The printer includes two test prints: the self test and the font list. Use these test prints to check the operation of the printer.

### ***Self Test***

You can print the self test in both printer control modes: BJ-10e mode or Epson LQ mode. The printer prints a repeating pattern of characters in the default print mode or pitch.

In BJ-10e mode, the pattern is printed in Courier typeface at 10 cpi; the print mode is HQ. In Epson LQ mode, the pattern is printed in Roman typeface at 10 cpi; the print mode is HQ.

#### ***Starting the test***

To start the self test, follow these steps:

1. Press the **POWER** button to turn off the printer.
2. Press and hold the **LF/FF** button, and press the **POWER** button until the beeper sounds.
3. When the printer beeps, release the **POWER** button. When it beeps again, release the **LF/FF** button. When the cartridge stops turning, the **POWER** and **ERROR** indicators light.



4. Insert a sheet of paper into the printer.



5. Press the **LF/FF** button. The printer positions the sheet of paper.
6. Press the **ON LINE** button. The printer starts to print the self test.

### ***Stopping the Test***

To stop the self test, press the **ON LINE** button.

To eject the sheet of paper, press **ON LINE** to set the printer off-line, and then press **LF/FF**.

### ***Pausing the Test***

To pause the self test, press the **LF/FF** button. The **ON LINE** indicator light blinks.

To resume press **LF/FF** again.

When the self test is paused, you can press **ON LINE** to set the printer on-line.





# Font List

You can print the font list in BJ-10e mode only. It is not available in Epson LQ mode. The font list shows Courier characters in several available print styles and pitches.

## ***Starting the font list***

To start printing the font list, follow these steps:

1. Press the **POWER** button to turn off the printer.
2. Press and hold the **PITCH** button, and press the **POWER** button until the beeper sounds.
3. When the printer beeps, release the **POWER** button. When it beeps again, release the **PITCH** button. The **POWER** and **ERROR** indicators light.
4. Insert a sheet of paper into the printer.



5. Press the **LF/FF** button. The printer positions the sheet of paper.
6. Press the **ON LINE** button. The printer starts to print the font list.

### Stopping the font list

To stop printing the font list, press the **ON LINE** button.

To eject the sheet of paper, press **ON LINE** to set the printer off-line, and then press **LF/FF**.

### Pausing the font list

To pause the printing of the font list, press the **PITCH** button.

To resume, press **PITCH** again.

When the font list is paused, you can press the **ON LINE** to set the printer on-line.

### Sample

In BJ-10e mode, the font list looks like this:

```

1
0123456789:;<=>?@ABCDEFGHIJKLMNPOQRSTUVWXYZ[\]^_`abcd
06AAAaAeAaEaE00000/0UcEWfAlóúñR@QZ

2
0123456789:;<=>?@ABCDEFGHIJKLMNPOQRSTUVWXYZ[\]^_`abcd
e00000p00000nFáíóúñR@QZ;=>?@ABCDEFGHIJKLMNPOQRSTUVWXYZ[\]^_`
06EFGHijklmnopqrstuvwxyz{|}~c06AAAaAeAaEaE00000/0UcEWfAlóúñR@QZ

3
0123456789:;<=>?@ABCDEFGHIJKLMNPOQRSTUVWXYZ[\]^_`abcd
06AAAaAeAaEaE00000p00000nFáíóúñR@QZ;=>?@ABCDEFGHIJKLMNPOQRSTUVWXYZ[\]^_`
06EFGHijklmnopqrstuvwxyz{|}~c06AAAaAeAaEaE00000/0UcEWfAlóúñR@QZ

4
0123456789:;<=>?@ABCDEFGHIJKLMNPOQRSTUVWXYZ[\]^_`abcd
06AAAaAeAaEaE00000p00000nFáíóúñR@QZ;=>?@ABCDEFGHIJKLMNPOQRSTUVWXYZ[\]^_`
06EFGHijklmnopqrstuvwxyz{|}~c06AAAaAeAaEaE00000/0UcEWfAlóúñR@QZ

5
0123456789:;<=>?@ABCDEFGHIJKLMNPOQRSTUVWXYZ[\]^_`abcd
e00000p00000nFáíóúñR@QZ;=>?@ABCDEFGHIJKLMNPOQRSTUVWXYZ[\]^_`
06EFGHijklmnopqrstuvwxyz{|}~c06AAAaAeAaEaE00000/0UcEWfAlóúñR@QZ

6
0123456789:;<=>?@ABCDEFGHIJKLMNPOQRSTUVWXYZ[\]^_`abcd
e00000p00000nFáíóúñR@QZ;=>?@ABCDEFGHIJKLMNPOQRSTUVWXYZ[\]^_`
06EFGHijklmnopqrstuvwxyz{|}~c06AAAaAeAaEaE00000/0UcEWfAlóúñR@QZ

7
0123456789:;<=>?@ABCDEFGHIJKLMNPOQRSTUVWXYZ[\]^_`abcd
e00000p00000nFáíóúñR@QZ;=>?@ABCDEFGHIJKLMNPOQRSTUVWXYZ[\]^_`
06EFGHijklmnopqrstuvwxyz{|}~c06AAAaAeAaEaE00000/0UcEWfAlóúñR@QZ

```



# Chapter 5

## Using the Printer With Software

---

Your printer will work with a wide variety of applications, such as spreadsheet, word processing, and graphics programs. This chapter describes how to set up your software application for your printer.

### ***Setting Up Windows 3.1 for Your Printer***

This section contains the procedures you perform to install the Bubble Jet Printer BJ-10e driver for Microsoft Windows operating system environment, version 3.1. Before you begin these procedures, make sure you are familiar with the basic operation of Windows including its terms and use of the mouse. If necessary, refer to your Microsoft Windows 3.1 User's Guide for help.

---



**NOTE:** If you are using any other version of Windows, call the Canon help desk at 1-800-423-2366 and ask them to send you the appropriate driver for your software.

---

### ***Installing the Printer Driver***

To install the printer driver, you will need your Windows installation diskettes. Make sure these diskettes are available.

1. Make sure your computer is turned on.
2. Start Windows.
3. Choose Control Panel from the Main Group window in the Program Manager.



# Chapter 5

## Using the Printer With Software

---

Your printer will work with a wide variety of applications, such as spreadsheet, word processing, and graphics programs. This chapter describes how to set up your software application for your printer.

### ***Setting Up Windows 3.1 for Your Printer***

This section contains the procedures you perform to install the Bubble Jet Printer BJ-10e driver for Microsoft Windows operating system environment, version 3.1. Before you begin these procedures, make sure you are familiar with the basic operation of Windows including its terms and use of the mouse. If necessary, refer to your Microsoft Windows 3.1 User's Guide for help.

---



**NOTE:** If you are using any other version of Windows, call the Canon help desk at 1-800-423-2366 and ask them to send you the appropriate driver for your software.

---

### ***Installing the Printer Driver***

To install the printer driver, you will need your Windows installation diskettes. Make sure these diskettes are available.

1. Make sure your computer is turned on.
2. Start Windows.
3. Choose Control Panel from the Main Group window in the Program Manager.





4. Open the Printers icon. The Printers dialog box appears.

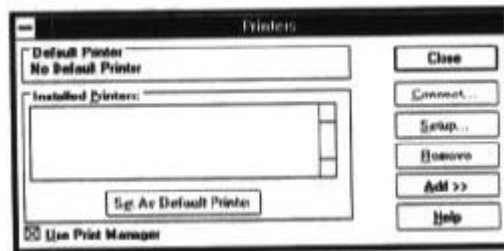

**NOTE:** Your screen may show printer in the Installed Printers box. This means other printers have been installed for your system; this is okay and should not cause any problems.

5. Choose the Add button to display the List of Printers box.
6. Scroll down the list until Canon Bubble Jet BJ-10e is highlighted, and then choose Install.

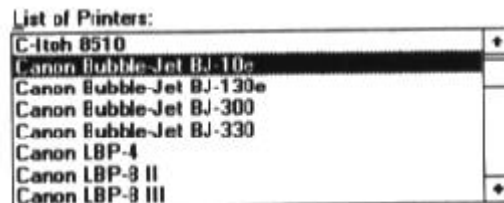

7. A dialog box appears instructing you to insert the Windows diskette that contains the printer driver. Insert the specified Windows 3.1 diskette into disk drive A: and select OK. (If you are not using drive A:, you can enter the path name that identifies the drive you are using or use Browse to locate the drive.)
8. The Control Panel installs the CANON10E.DRV file on your hard disk. The printer dialog box appears with the Canon Bubble Jet BJ-10e listed in the Installed Printer box. (See the screen on the next page.)

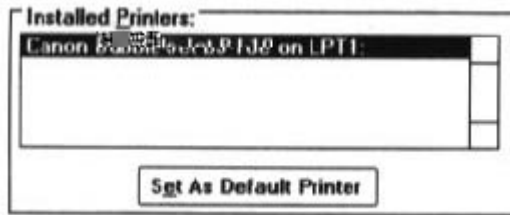

9. If you need to change the port designation, make sure the Canon Bubble Jet BJ-10e is selected in the Installed Printer box. Then select the Connect button to display the Connect dialog box.

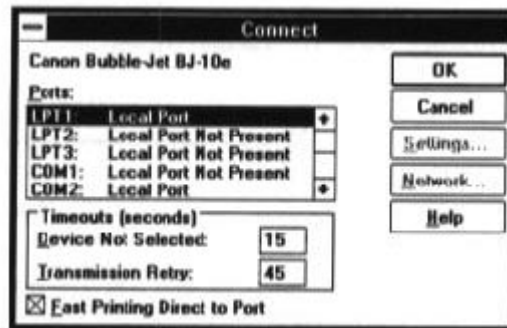

10. Choose your port and select OK.
11. If you want to use the Bubble Jet Printer BJ-10sx for all of your work, make sure Canon Bubble Jet BJ-10e is highlighted and select the Set As Default Printer button from the Printers dialog box.
12. If you have not installed an optional sheet feeder, turn off the Print Manager. To do so, clear the Use Print Manager check box at the bottom of the Printers dialog box by clicking on the check box.

Now run the printer setup program described in the next section. After running Setup, select the Close button to complete the installation of the Canon Bubble Jet Printer BJ-10e Windows driver.



## Printer Setup Within Windows

After you install the Canon Bubble Jet BJ-10e printer driver, be sure to run the printer setup program to customize the printer settings. This program is located in the printer's control panel. Select the Setup button.

When you start the Setup program, Windows displays the main dialog box for you printer.

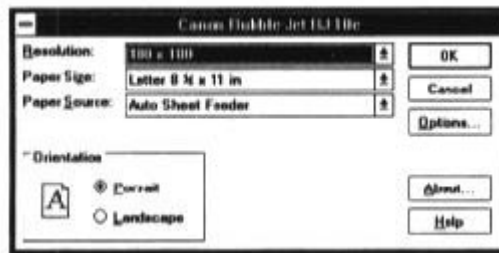

From this screen, you can select your resolution, paper size, and orientation. You can also display About and Help information, and select other Options.

- Click on the arrow next to the Resolution setting to select one of the following resolutions:

180 x 180 dots per inch (dpi), which is the default resolution  
360 x 360 dpi  
120 x 180 dpi



---

**NOTE:** To get the best print quality, change this setting to 360 x 360.

---

- Click on the arrow next to the Paper Size setting to select one of the following paper sizes:

Letter 8 1/2 x 11 in, which is the default  
Legal 8 1/2 x 14 in  
A4 210 x 297 mm  
B5 182 x 257 mm

- Click on the arrow next to the Paper Source setting to select one of the following paper sources:

Auto Sheet Feeder, which is the default  
Manual Feed

---

**NOTE:** If you have not installed an optional sheet feeder, change this setting to Manual Feed.



- You can select either Portrait or Landscape orientation by clicking on the appropriate selection in the Orientation box. The default is portrait orientation.
- Click on About in the main dialog box to display copyright information regarding the Windows driver and its version number.
- Click on Help in the main dialog box to enter Microsoft's Universal Driver Help program. The Printer Setup screen displays information that will help you specify your printer settings.

## Options

As part of your printer setup, you can specify certain options that control the darkness and fineness of your printed graphics and text.

Click on Options in the main dialog box to display the Options dialog box:

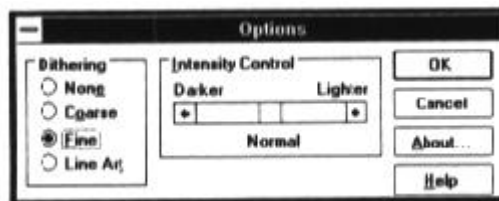

From this screen you can select a dithering pattern and an intensity level. You can also display About and Help information.



- You can select one of four dithering patterns: None, Course, Fine, or Line Art. None causes all color values to threshold to either black or white; no in-between-colors will be represented. The default dither pattern is Fine.
- You can control the intensity with which text is printed on your printer using the Intensity Control Box. This controls the threshold at which a pixel value is turned on or off. Setting the slide bar to the left prints darker and setting it to the right prints lighter. This control affects all dithering options. The default is the value represented at the center of the slide bar. (In some applications, setting the slide bar all the way to the right causes nothing to print.)
- Click on About in the Options dialog box to display copyright information regarding the Windows driver and its version number.
- Click on Help in the Options dialog box to enter Microsoft's Universal Driver Help program. The Options screen displays information that will help you specify your printer options.

## ***Printing a Document***

This procedure provides the general printing guidelines for many of the application you may run in the Windows environment. The exact steps for printing a document may vary depending on the application program you are using. Refer to your program's documentation for the exact printing procedure.

1. Start the program you used to create the document, and open the document you want to print.
2. Choose Printer Setup from the File menu.
3. Select the Canon Bubble Jet BJ-10e as your printer, and select Setup.
4. Make any adjustments as appropriate for printing your document, and select OK.
5. Select OK to close the Printer Setup window.



6. Choose Print from the File menu.
7. After making any necessary changes to the printing parameters, select OK to start the print job.



**NOTE:** Be sure to turn off the Print Manager if you are feeding paper manually. To do so, clear the Use Print Manager check box in the Printers dialog box.

---

## ***Setting Up Other Software Applications***

If you are not using Windows, follow the guidelines in this section for setting up your applications for use with the Bubble Jet Printer BJ-10sx. If you installed the Canon Bubble Jet BJ-10e Windows printer driver as described in the previous section and will be printing only under Windows, you can ignore this information.

Software applications are designed to work with specific hardware setups. Most application programs include an installation program or routine that you run to tell the software what type of hardware you are using, such as your computer and printer.

Application programs include a group of programs, called printer drivers, that support different printers. Before using the printer with your application program, you need to tell the application what type of printer you are using by selecting the printer driver that corresponds to your printer.

### ***Selecting a Printer Driver***

The installation programs for most applications offer a list of printer drivers from which to choose. If you find Canon BJ-10sx, BJ-10e, or BJ-10ex on the list, select it. This gives you the fullest range of features.

If you do not find one of these printers on the list, you can select a printer that will have nearly the same operational capabilities as the Bubble Jet Printer BJ-10sx.





---

**NOTE:** Software developers continuously create printer drivers. If your application software does not list a Canon BJ-10sx driver, call your software application's technical support line and ask if a BJ-10sx driver is available. If they are unable to assist you, please call the Canon help desk at 1-800-423-2366 to see if a driver is available.

---

To use the printer in BJ-10e mode, select one of the following printer (they are all listed in order of preference):

Canon BJ-10sx (X24E)  
Canon BJ-10e/BJ-10ex (X24E)  
IBM Proprinter X24E/XL24E  
IBM Proprinter X24E/XL24  
Canon BJ-130e  
IBM Proprinter  
IBM Graphics Printer

---



**NOTE:** If you select Canon BJ-130e, you must set DIP switch 10 to ON; see Chapter 8, Customizing the Printer, for details.

---

To use the printer in Epson LQ mode, select one of the following printer (they are listed in order of preference):

Canon BJ-10sx (LQ)  
Canon BJ-10ex (LQ)  
Epson LQ-510  
Epson LQ-850  
Epson LQ-500  
Epson LQ printer  
Epson FX or MX printer

After choosing a printer, you can use software commands through your application program to select all the standard printer functions. This includes bold or double-strike printing, underlining, subscripts, margin control, line-spacing control, and graphics.

◀ BACK

NEXT ▶

▶ BACK TO START

## ***Selecting a Printer Control Mode***

Your printer has two resident printer control modes: BJ-10e mode and Epson LQ mode. BJ-10e mode is the default.

If you select a Canon BJ printer or the IBM Proprinter X24E through your application program, use the printer in BJ-10e mode. This mode gives you the fullest range of features.

If your application program does not support a Canon BJ printer or IBM Proprinter X24E, but does support an Epson LQ printer, you can use the printer in LQ mode.

You can also select a printer control mode based on specific text features you want to use in your document. If you will be printing only text (no graphics), select LQ mode if Epson drivers are available. If you plan to print both text and graphics, select BJ-10e mode.

You use DIP switch 11 to select the printer control mode. When DIP switch 11 is OFF, which is the default, the printer uses BJ-10e mode. Set DIP switch 11 to ON and select LQ mode. See Chapter 8, *Customizing the Printer*, for more information on DIP switches.

## ***Software and Printer Compatibility***

You use software to send information and instructions to the printer over the cable that connects the printer to the computer. In addition to data, the instructions you send may include special command sequences known as control codes and ESCape sequences. These command sequences tell the printer such things as how many lines to skip and where to start printing.

Some control codes are standard throughout the microcomputer industry and are recognized by all printers. Two examples of these are form feed (FF) and line feed (LF).

ESCape sequences are unique to each printer emulation. ESCape sequences begin with the ESCape characters (ESC) followed by one or more other characters.

The ESCape character tells the printer not to print the next character(s), but to use the information to perform a printing control task, such as printing in bold or underlining.



Appendix C, Printer Mode Command Summaries and Character Sets, lists the control codes and ESCape sequences the printer recognizes in both BJ-10e mode and Epson LQ mode. The printer recognizes control sequences in ASCII, decimal, and hexadecimal format.

---



**NOTE:** You can enter a command in ASCII format provided the decimal equivalent of the command is a number greater than 32. In all other cases, you must enter the decimal format of the command.

---

How you enter the control codes and ESCape sequences depends on your application software. Also, your application software may require that the codes and sequences be entered in a specific format, such as decimal rather than hexadecimal. For example, you can use only decimal format with Multimate Advantage II, Professional Write, and PFS: First Choice.



**NOTE:** Application printer drivers may override the printer control codes embedded in a document. This means the command will not take effect because of the way the application handled it.

---

To determine if an application is overriding your commands, print the document using a generic driver and see if the correct commands are reflected in the printed copy. If they are, the application printer driver is overriding the commands.

# Chapter 6

## Maintaining the Printer

---

This chapter covers the care and maintenance of your printer. This includes cautions, cleaning the printer, replacing the ink cartridge, and storing the printer.

### ***Cautions***



Follow these guidelines to avoid damage to your printer and harm to you or others:

- Set the printer on a stable surface before printing
- Do not set anything on top of the printer.
- Make sure the power is off any time you connect or disconnect the AC adapter or interface cable.
- Do not move the mechanism that holds the ink cartridge. You may damage delicate mechanical parts.
- Do not touch the print head area on the ink cartridge. You may damage the print head.

### ***Cleaning the Printer***

To achieve the maximum performance from your printer, clean it regularly.

Be very careful when cleaning the printer. Follow these steps:

1. Make sure the printer is turned off.
2. Unplug the AC adapter from the wall outlet.
3. Disconnect the AC adapter and the interface cable from the printer.

◀ BACK

NEXT ▶

▶ BACK TO START

4. Open the top cover and then open the inner cover.

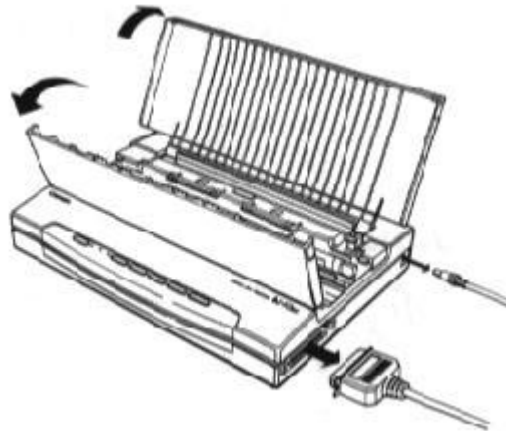

5. Clean the inside of the printer using canned air or a soft cloth to remove any ink mist or paper debris

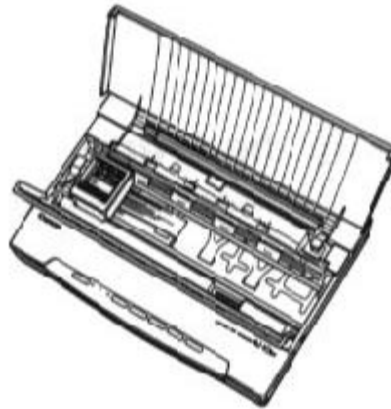

Be sure to clean the areas where the covers are attached to the printer case; ink mist may accumulate in these areas.



6. Clean the exterior of the printer with a soft cloth moistened with water. Wipe any smudges or dust.



---

**CAUTION:**

- Make sure the printer is turned off before cleaning it.
  - When cleaning inside the printer, avoid the area near the print head on the ink cartridge. Do not touch the print head. Ink may leak out and cause stains.
  - Do not use any oil or cleanser inside the printer.
  - Use a soft cloth to clean the printer; do not use paper towels or tissues.
  - Do not clean the exterior of the printer with volatile liquids, such as thinners or benzene, or any other spray-type or chemical cleaner. Chemicals may damage the surface of the printer
  - Do not submerge the printer in water
- 

## ***Replacing the Ink Cartridge***

The ink cartridge you use with the printer is BC-01. Each ink cartridge contains enough ink to print about 400 to 500 pages (700,000 characters) in HQ mode, and 800 to 1000 pages (1,400,000 characters) in economy mode. The actual amount varies according to the print density of a page. If you print a lot of graphics, you may need to change ink cartridges more often.

You need to replace the ink cartridge when either of the following conditions exist:

- You have been using the ink cartridge for over one year.
- Your printed output is not crisp and clear, or there are gaps in the characters (missing dots).



If your print quality is not crisp and clear, be sure to clean the print head before determining whether you need to replace the cartridge. If you clean the print head several times and your print quality does not improve, you need to replace the cartridge.

There are two print head cleaning procedures -- one for a new ink cartridge (described later in this chapter ) and one for print quality problems (described in Chapter 7, Troubleshooting).



**NOTE:** Print head cleaning is not a routine maintenance procedure. Only clean the print head if you are installing a new ink cartridge or your print quality is inadequate.

---

## ***Installing the Ink Cartridge***

---



**CAUTION:** Canon makes two ink cartridges that fit the printer; the BC-01 is designed specifically for the Bubble Jet Printer BJ-10sx. There fore, use only the BC-01 cartridge with this printer.

---

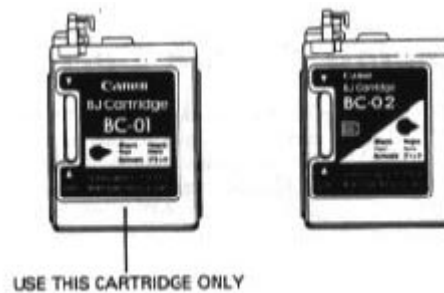

To avoid spilling ink, follow these precautions:

- Do not touch the print head on the ink cartridge or the sharp edges around it.
- Do not hold the ink cartridge, or place it on a surface, with the print head facing down.

- Do not attempt to disassemble the cartridge.
- Do not vigorously shake the cartridge while handling it.
- Remove the ink cartridge from the printer only when necessary.



**CAUTION:** Keep the ink cartridge out of the reach of children; the ink contains isopropyl alcohol 67-63-0.

---

To install a new ink cartridge, follow these steps:

1. Make sure the printer is turned off.
2. Open the top cover and then open the inner cover.
3. Lift the green lock lever on the cartridge holder. Slide the old ink cartridge out of the holder and dispose of it properly.

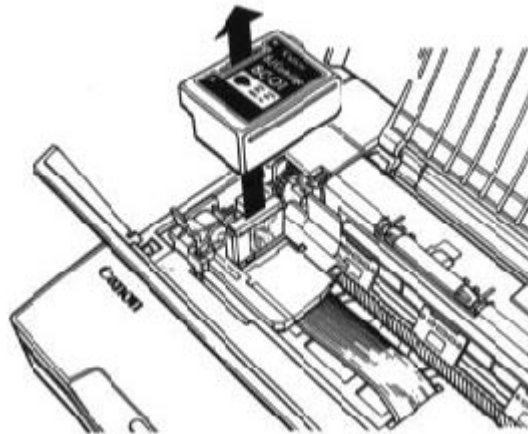

◀ BACK

NEXT ▶

▶ BACK TO START

4. Unpack the new ink cartridge from its protective packaging. Snap off the orange cap from the print head and then remove the orange tape.

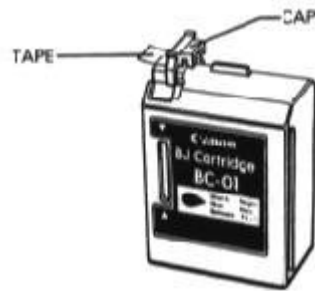

5. Fit the ink cartridge over the yellow mounting base with the print head facing the back of the printer.

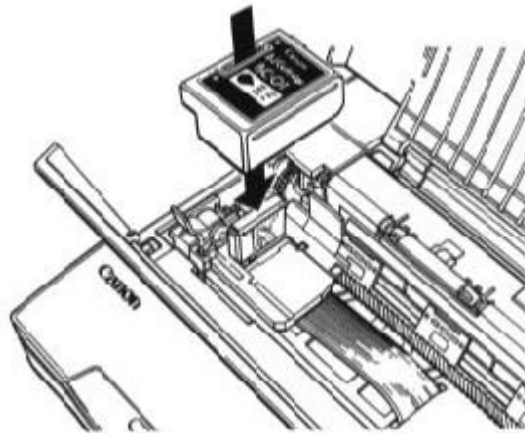

---

**CAUTION:** Avoid touching the yellow mounting base on which you place the cartridge -- especially the circuit board on the side of the mounting base and the film cable that extends from the cartridge holder.

---

6. Push the lock lever back until it snaps into place. This secures the ink cartridge so it makes contact with the circuit board on the cartridge holder.

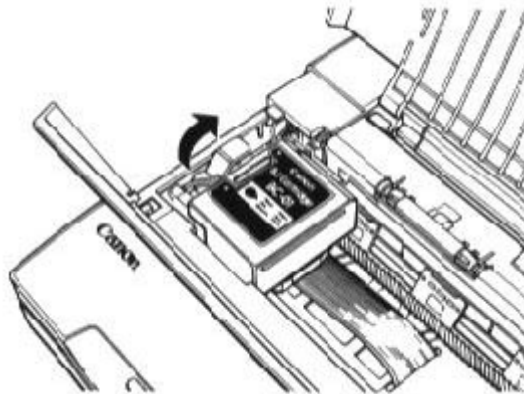

**CAUTION:** Do not move the ink cartridge after it is installed. Moving the ink cartridge to the right and leaving it there may uncap the print head and cause it to dry out.

7. Close the inner cover and then close the top cover.

When you are not using the printer, make sure the ink cartridge is in its home position, which is on the left side of the printer.

## ***Cleaning the Print Head***



**NOTE:** The print head on a new ink cartridge needs to be cleaned to ensure that you get the best possible print quality. This section describes a simple procedure for cleaning the print head on a new ink cartridge. If you are having print quality problems, see the more detailed cleaning procedure described in Chapter 7, Troubleshooting.

◀ BACK

NEXT ▶

▲ BACK TO START



The printer automatically cleans the print head when you follow these steps:

1. Make sure the printer is turned off
2. Press and hold the **FWD ADJ** and **REV ADJ** buttons, and press the **POWER** button until you hear the printer beeps.
3. When the printer beeps, release the **POWER** button.
4. When the printer beeps again, release the **FWD ADJ** and **REV ADJ** buttons.

After several seconds, the **ON LINE** indicator light starts to blink. It blinks for about five seconds while the printer cleans the print head. When complete, the **ON LINE** indicator light stops blinking and stays on.



You can repeat this procedure if your printed output includes white streaks, missing dots, or irregular dots. If you have continual print quality problems, see Chapter 7, Troubleshooting, for a more detailed procedure that allows you to visually check the results of the print head cleaning.

---

**NOTE:** Cleaning the print head consumes a small amount of ink. Repeating this procedure unnecessarily reduces the life of the ink cartridge.

---

## Storing Ink Cartridges

Follow these guidelines when storing your ink cartridges:

- Keep a new ink cartridge in its sealed container until you are ready to use it.
- Store the ink cartridge at room temperature.
- Install the ink cartridge in the printer immediately after you open the sealed container.
- After installing the ink cartridge, be sure to perform the print head cleaning procedure.

## Storing the Printer

Before storing the printer, follow these steps to protect the print mechanism:

1. Turn off the power. This secures the print head in the home position.
2. Remove any paper from the printer.
3. Disconnect the interface cable and the AC adapter.
4. If an optional battery pack is installed, turn off the battery switch and remove the battery pack.
5. If the optional sheet feeder is installed, remove it.
6. Close the covers, if necessary.
7. Repack the printer in its original packing materials.



---

**NOTE:** The printer is designed to be stored with the ink cartridge installed. Therefore, do not remove the ink cartridge. An opened ink cartridge that is not installed in the printer may leak, and the print head may dry out.

---

◀ BACK

NEXT ▶

▶ BACK TO START

# Chapter 7

## Troubleshooting

---

This chapter contains information to help you solve printer problems. A problem may have one or a combination of causes, including a malfunction in your computer, software, the printer cable, or the printer. Many printing problems are related to how your software interacts with the printer.

If your printer is not operating properly, try the suggestion in this chapter to isolate and solve the problem.



---

**NOTE:** If you have a problem with your printer and you cannot resolve it by referring to the information in this chapter, contact the Canon Computer System Technical Support help desk at 1-800-423-2366. Attempting to repair the printer yourself may void the warranty.

---

### *Checking the Indicator Lights*

If you have a problem with your printer, check the indicator lights. The indicator lights and the printer alarm notify you of the following problems:

#### Lights

<u>POWER</u>	<u>ON</u> <u>LINE</u>	<u>ERROR</u>	<u>Printer</u> <u>Alarm</u>
Off	Off	Off	None

**Problem:** AC adapter is not connected.

**Solution:** Make sure the AC adapter is connected securely to the printer and to the wall outlet.

**Problem:** Printer is not turned on.

**Solution:** Turn on the printer.

◀ BACK

NEXT ▶

▶ BACK TO START

## Lights

---

<u>POWER</u>	<u>ON LINE</u>	<u>ERROR</u>	<u>Printer Alarm</u>
On	Off	On	Beeps twice in BJ-10e mode, three times in LQ mode

**Problem:** No Paper is loaded.

**Solution:** Load Paper.

---

<u>POWER</u>	<u>ON LINE</u>	<u>ERROR</u>	<u>Printer Alarm</u>
On	Off	On	Beeps continuously

**Problem:** Paper is jammed in the printer.

**Solution:** Clear the paper jam as described later in this chapter.

**Problem:** Paper loaded in the printer is longer than 15 inches.

**Solution:** Remove the paper, and use paper that matches the specifications of the printer. See Appendix A, Printer Specifications, for details.

---

<u>POWER</u>	<u>ON LINE</u>	<u>ERROR</u>	<u>Printer Alarm</u>
On	Off	Blinks	Beeps continuously.

**Problem:** The carriage has not returned to its home position.

**Solution:** Turn off the printer, wait at least four seconds, and then turn on the printer.

---

<u>POWER</u>	<u>ON LINE</u>	<u>ERROR</u>	<u>Printer Alarm</u>
On	Blink	Off	Beeps five times

**Problem:** A software error has occurred.

**Solution:** Turn off the printer, wait at least four seconds, and then turn on the printer.

---

<u>POWER</u>	<u>ON LINE</u>	<u>ERROR</u>	<u>Printer Alarm</u>
On	Blink	Off	Beeps continuously

**Problem:** A software error has occurred when the printer was starting up.

**Solution:** Turn off the printer, wait at least four seconds, and then turn on the printer.

---

**POWER ON LINE ERROR Printer Alarm**

On            Blinks            Blinks            Beeps three times

**Problem:** A software error has occurred.

**Solution:** Turn off the printer, wait at least four seconds, and then turn on the printer.



## Lights

<u>POWER</u>	<u>ON LINE</u>	<u>ERROR</u>	<u>Printer Alarm</u>
Blinks every 0.5 seconds	Off	Off	None

**Problem:** The optional battery pack is low.

**Solution:** Recharge the battery pack. (The battery pack is described in Chapter 9, Installing a Options.)

---

## POWER ON LINE ERROR Printer Alarm

Blinks every 0.5 seconds    Off    On    Beeps five times; after five minutes, the printer beeps again and then turns off every 0.5 seconds

**Problem:** The optional battery pack is fully discharged.

**Solution:** Recharge the battery pack. (The battery pack is described in Chapter 9, Installing a Options.)

---

<u>POWER</u>	<u>ON LINE</u>	<u>ERROR</u>	<u>Printer Alarm</u>
Blinks	Off	Blinks	Beeps five times

**Problem:** The optional battery pack is fully discharged.

**Solution:** Recharge the battery pack. (The battery pack is described in Chapter 9, Installing a Options.)

## ***Printing the Self Test***

If you have a problem with your printer that you cannot solve by checking the indicator lights, try to print the self test as described in Chapter 4, Using the Operator Panel. If you can print the self test, the problem is not with the printer. Check the following:

1. Check the interface cable connection. Make sure you have connected the correct interface cable to your computer and that the connections are secure.
2. Make sure the computer is set up correctly for your printer.
3. Print a screen dump from your computer. If it does not print, there is a problem with your software or the interface port. Call the Canon Help desk at 1-800-423-2366.

## Print Quality Problems

If your print quality is not what you expect it to be, check the following list for your problem and a possible remedy.

<u>Print results</u>	<u>Most probable cause</u>	<u>Remedy</u>
Blurred character	Paper type	Try a different paper type; use paper that meets the printer's specifications.
Faded print	Print head is clogged or out of ink	Clean the print head or replace the ink cartridge.
Light characters	Printer is in economy mode	Set the printer to HQ mode.
White streaks	Print head is clogged	Clean the print head.
Dots missing	Print head is clogged	Clean the print head
Irregular dots	Print head is clogged	Clean the print head
Print appears dirty	Paper thickness dial needs to be adjusted	Adjust the paper thickness dial for the type of paper you are using.

The print head cleaning procedure is described later in this chapter.

---

**NOTE:** If you are using Windows and your output appears jagged, run the printer setup program and make sure the resolution setting is 360 x 360 dpi.

---

## Paper Loading Problems

To avoid paper loading problems, follow these guidelines:

- Only use paper that matches the printer's specifications. See Appendix A, Printer Specifications, for details.
- Make sure the inner cover is closed.
- Make sure the paper release lever is pressed all the way down.
- Make sure the sheet of paper is straight in the printer.

# ***Printing Problems***

This section contains problems and solutions related to your printer or the software you are using.

## ***Printout Is Wrong***

If strange characters appear in your output, there may be a communications problem between the printer and your computer.

If your printed output does not appear as you expect, follow these steps:

1. Check that your cable connections are secure
2. Check that the printer control mode (BJ-10e or Epson LQ) matches the printer driver you selected in your software application.

## ***Characters On the Screen Do Not Match the Printed Characters***

Many graphics characters and special symbols are produced by different ASCII codes on each make of computer and printer. Compare the character set in your computer manual with the printer character sets shown in Appendix C, Printer Mode Command Summaries and Character Sets. Set the correct character set and printer control mode with the DIP switches. See Chapter 8, Customizing the Printer, for information about changing DIP switch settings.

## ***Printer Is Not Using the Font You Selected With DIP Switches***

Your software is overriding the DIP switch settings. Change the initialization or setup string that your software sends. You may need to do this using a menu or screen provided by your application software. See your application user's manual for information about how your software works with your printer.





## ***Computer Indicates a Device Time-Out***

A device time-out occurs when your computer sends data to the printer but the printer does not respond. The printer may be off, off-line, or not connected to the computer.

If your computer indicates a device time-out, follow these steps:

1. Make sure the printer is on and on-line.
2. Make sure the printer's interface cable is securely attached to both the printer and the computer.
3. Make sure paper is properly loaded.
4. Try the print operation again.

## ***Clearing Paper Jams***

If a paper jam occurs, the **ERROR** indicator will light and the printer will go off-line.

### ***Feeding Paper From the Top***

If you are feeding paper in the top slot and it becomes jammed, follow these steps to clear the paper jam:

1. Pull up the paper release lever to unlock it.

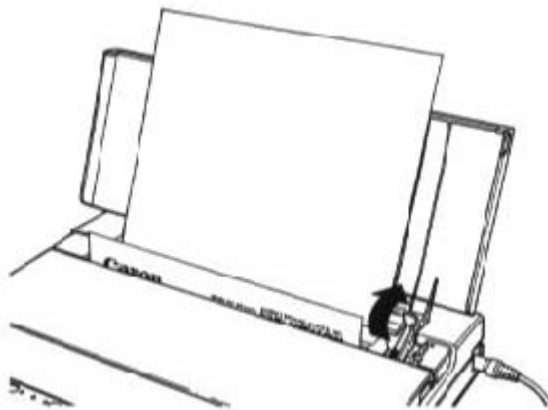

2. Gently pull out the sheet of paper with one hand while holding down the printer with your other hand. pull out the paper from the front of the printer.

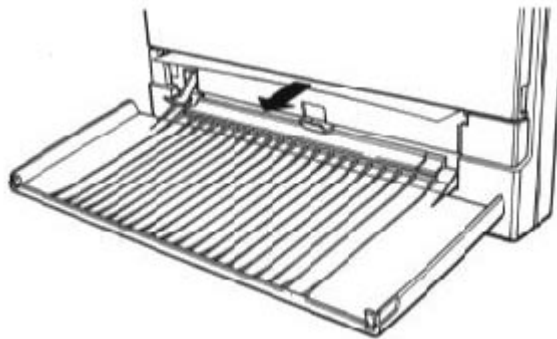

If the paper does not release, press the **FWD ADJ** button while you pull the jammed sheet from the front of the printer. Press the **REV ADJ** button if you are pulling the jammed sheet from the back of the printer.

3. After clearing the jammed sheet, press the paper release lever back to its locked position.



---

**NOTE:** If ink gets on the platen when you clearing a jammed sheet of paper, clean it by feeding a few sheets of paper through the printer before printing.

---

If you are having repeated paper jams, it may be due to the paper you are using. Be sure the paper you are using and your printing environment are within the specifications of the Bubble Jet Printer BJ-10sx. See Appendix A, Printer Specifications, for details.

## ***Cleaning the Print Head***

If you are having print quality problems, you need to clean the print head. Paper dust or ink may get clogged in an ink nozzle in the ink cartridge. Performing the print head cleaning procedure should clear up this problem.

The printer automatically cleans the print head when you follow these steps:

1. Turn on the printer. The **POWER** and **ERROR** indicators come on.
2. Open the top cover and insert a sheet of paper into the printer.
3. Press the **LF/FF** button to advance the paper.
4. Press the **ON LINE** button. The **ON LINE** indicator lights.
5. Press the **FWD ADJ** and **REV ADJ** buttons at the same time. The printer beeps.
6. Immediately press the **LF/FF** button. (The printer beeps.) The printer cleans the print head and prints a check pattern.



If the printer beeps before you press the **LF/FF** button, it will clean the print head but not print the check pattern.

Inspect the check pattern. There should be a horizontal line between each pair of vertical lines. If any horizontal is missing, repeat the cleaning process until all lines are present.



If the quality of your printed output is still not crisp and clear after cleaning the print head, try the cleaning procedure again. If your output is not satisfactory after cleaning the print head several times, replace the ink cartridge.

---

**NOTE:** Cleaning the print head consumes a small amount of ink. Repeating this procedure unnecessarily reduces the life of the ink cartridge.

---

◀ BACK

NEXT ▶

▶ BACK TO START

# Chapter 8

## Customizing the Printer

---

This chapter describes the factory default settings of the printer and the steps you follow to customize these settings for your particular printing needs.

You will find that the factory default settings provide features to meet most of your printing needs. With these settings, your printer operates in BJ-10e mode to emulate the IBM Proprinter X24E. This means you can use the printer with any software application that support this printer.

You want to make sure the printer's settings match the requirements of your software application. If you do have a unique printing requirement, you can customize the printer by changing the DIP switch settings as described in this chapter.

Your printer is designed to be used in BJ-10e mode and provides numerous printing features in this mode. If your software application is designed to print only on a n Epson LQ printer, you can use the DIP switches to change the printer mode to Epson LQ.

### ***Factory Default Settings***

The following table shows the factory default settings of the printer.

<b><u>Function</u></b>	<b><u>Setting</u></b>
Character pitch	10 characters per inch (cpi)
Line spacing	6 lines per inch (lpi)
Print quality	High quality (HQ) mode
Print direction	Bi-directional
Font typeface	Courier
Text scale mode	Disabled
Alternate Graphics Mode	Disabled
Page length	11 inches (279 mm)



<b><u>Function</u></b>	<b><u>Setting</u></b>
Code page	437 (USA)
Character set	Character Set 1
Horizontal tab stops	Every 8 columns
Buffer	Input = 37 KB Download = 0 KB
Printer control mode	BJ-10e
Emulation	IBM X24E

This printer has two control modes: BJ-10e mode, which emulates the IBM Proprinter X24E or the Canon BJ-130e, and Epson LQ mode, which emulates the Epson LQ-510. The default setting is BJ-10e mode. If you change this to Epson LQ mode, the default settings also change.

## ***DIP Switch Settings***

The DIP switch settings control various printer functions, such as the page length and character set you want to use. The DIP switches are located on the inside of the printer under the paper cover.

A DIP switch is OFF when it is down, and ON when it is up. The factory default setting for each DIP switch is OFF.

The printer function defined by the DIP switches are determined by the printer control mode. DIP switch 11 selects the printer control mode. When DIP switch 11 is OFF, the printer is in BJ-10e mode; when DIP switch 11 is ON, the printer is in Epson LQ mode.

## ***Changing a DIP Switch Setting***

To change the DIP switch setting, follow these steps:

1. Make sure the printer is turned off.



2. Open the top cover and then open the inner cover.



3. Use a pointed object, such as a ballpoint pen, to change the DIP switch settings. A DIP switch is OFF when it is down, and ON when it is up.

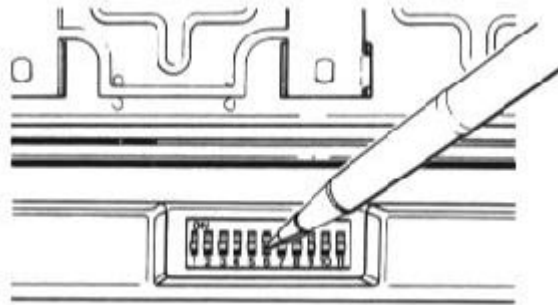

4. After making your selections, close the inner cover and then close the top cover.

The new DIP switch settings take effect when you turn on the printer.

If you turn off or reset the printer, or if the printer receives the Set

## ***BJ-10e Mode***

**DIP switch 1**

If you install the optional sheet feeder, set this DIP switch to ON.

**DIP switch 2**

If you are using a software application that assumes 66 lines will fit on each page, set this switch to ON. The printer reduces the line spacing by a factor of 14/14, which is from 63 lines per pages to 66 lines per page if line spacing is set to 6 lines per inch (lpi). This function is available only when line spacing is 6 lpi or 8 lpi.

**DIP switch 3**

When this switch is OFF, the printer performs a normal carriage return (CR). Set this switch to ON if you want the printer to perform a line feed after each carriage return (CR + LF).

**DIP switch 4**

If you are using letter-size paper, set this switch OFF; this sets the page length to 11 inches. If you are using A4-size paper, set this switch ON; this sets the page length to 12 inches.

**DIP switch 5**

When this switch is OFF, the printer uses Character Set 1. When this switch is ON, the printer uses Character Set 2. See Appendix C, Printer Mode Command Summaries and Character Sets, for information on the character set.

**DIP switch 6**

When this switch is OFF, the printer performs a normal line feed (LF). Set this switch to ON if you want the printer to perform a carriage return after each line feed (LF + CR).

**DIP switch 7**

Set this switch ON to enable Alternate Graphics Mode (AGM). In this mode, the printer accepts high-resolution, 24-dot, all-points-addressable (APA) graphics commands similar to those used with conventional 24-pin printers.

**DIP switch 8**

When this switch is OFF, the printer allocates the entire buffer space (37 KB) to the input buffer. When you are using downloaded fonts, change this switch to ON; the printer allocates 34 KB of buffer space for downloaded fonts.



### **DIP switch 9**

When this switch is OFF, the printer uses USA code page 437.  
When this switch is ON, the printer uses Multilingual code page 850.  
Each code page has three character sets: Set 1, Set 2, and the All Characters Chart. See Appendix C, Printer Mode Command Summaries and Character Sets, for a sample of each character set.

### **DIP switch 10**

When this switch is OFF, the printer emulates the IBM Proprinter X24E. When this switch is ON, the printer emulates the Canon BJ-130e.

### **DIP switch 11**

When this switch is OFF, the printer is in BJ-10e mode. When this switch is ON, the printer is in Epson LQ mode.

## ***Epson LQ Mode***

When the printer is in Epson LQ mode (DIP switch 11 is ON), you can set the DIP switches to control the following functions:

<b>DIP switch</b>	<b>Function</b>	<b>OFF</b>	<b>ON</b>
1	Automatic sheet feeder	Disable	Enable
2	Text scale mode	Disabled	Enabled
3	Automatic line feed (LF)	Normal CR	CR + LF
4	Page length	11 inches (279 mm)	12 inches (305 mm)
5	Character set	Italics	Graphics
6, 7, 8	International character set	See below	
9, 10	Typeface	See below	
11	Printer control mode	BJ-10e mode	Epson LQ mode

### **DIP switch 1**

If you install the optional sheet feeder, set this DIP switch ON.



### **DIP switch 2**

If you are using a software application that assumes 66 lines will fit on each page, set this switch to ON. The printer reduces the line spacing by a factor of 14/15, which is from 63 lines per page to 66 lines per page if line spacing is set to 6 lines per inch (lpi). This function is available only when line spacing is 6 lpi or 8 lpi.

### **DIP switch 3**

When this switch is OFF, the printer performs a normal carriage return (CR). Set this switch to ON if you want the printer to perform a line feed after each carriage return (CR + LF).

### **DIP switch 4**

If you are using letter-size paper, set this switch OFF; this sets the page length to 11 inches. If you are using A4-size paper, set this switch ON; this sets the page length to 12 inches.

### **DIP switch 5**

When this switch is OFF, the printer uses the Epson Italics character set, which includes italic characters. When this switch is ON, the printer uses the Epson Graphics character set, which is the same as the IBM USA code page 437 (this character set includes symbols, lines, corners, and European characters). See Appendix C, Printer Mode Command Summaries and Character Sets, for information on the character sets.

### **DIP switch 6, 7, 8**

These switches allow you to select one of eight international character sets. These character sets provide you with the characters and symbols used in other languages. See Appendix C, Printer Mode Command Summaries and Character Sets, for information on the character sets.

<b><u>Character Set</u></b>	<b><u>DIP switches</u></b>		
	<b><u>6</u></b>	<b><u>7</u></b>	<b><u>8</u></b>
USA	OFF	OFF	OFF
United Kingdom	OFF	OFF	ON
Germany	OFF	ON	OFF
France	OFF	ON	ON
Denmark	ON	OFF	OFF
Sweden	ON	OFF	ON
Italy	ON	ON	OFF
Spain	ON	ON	ON

### **DIP switches 9, 10**

These switches allow you to select one of three font typefaces.

<u>Typeface</u>	<u>DIP switches</u>	
	<u>9</u>	<u>10</u>
Roman	OFF	OFF
Sans serif	OFF	ON
Draft	ON	**

\*\* When DIP switch 9 is ON, the printer is in draft mode regardless of the setting of DIP switch 10.



#### **NOTE:**

- The printer uses the font specified by your software application regardless of the DIP switch settings.
- The Roman and Sans serif fonts appear slightly different than they would if printed on the Epson LQ-510.

---

### **DIP switch 11**

When this switch is OFF, the printer is in BJ-10e mode. When this switch is ON, the printer is in Epson LQ mode.

# Chapter 9

## Installing and Using Options

---

This chapter describes how to install and use the options you can purchase for your Canon Bubble Jet Printer BJ-10sx.

### ***Sheet Feeder***

Two types of sheet feeders are available for the printer. These sheet feeders allow you to automatically feed stacks of paper.

The Canon ASF-6410 sheet feeder holds up to 30 sheets of paper, and the Canon ASF-6420 sheet feeder holds up to 50 sheets of paper.

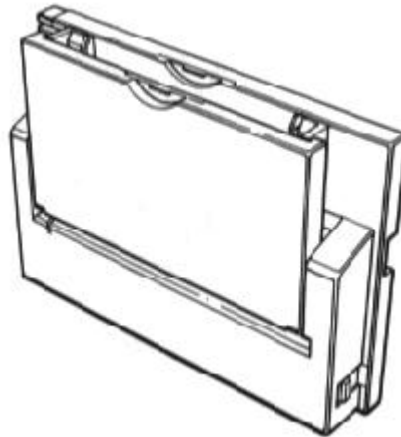

See Appendix A, Printer Specifications, for the specifications of these optional sheet feeders.



## ***Installing the Sheet Feeder***

To install the optional sheet feeder, follow these steps:

1. Make sure the printer is turned off and the top cover is closed.
2. Position the printer stand so it is perpendicular to the printer, and set the printer on its back.
3. Align the sheet feeder with the printer so the hooks on the sheet feeder fit into the slots on the bottom of the printer. Press the locks on the sides of the sheet feeder toward the printer to lock the sheet feeder into place.

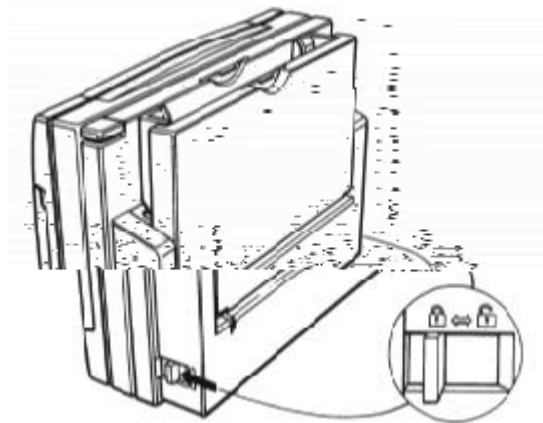

## ***Loading Paper in the Sheet Feeder***

You can load up to 30 or 50 sheets (depending on your model) of normal-weight paper in the sheet feeder. The paper bin must be closed when you load paper.

1. Make sure the paper bin is closed.
2. Extend the paper supports on the sheet feeder.
3. Fan a stack of paper.



4. Insert the stack of paper into the sheet feeder.
5. Open the bin by pressing the bin release button on the sheet feeder. (the bin release lever is on the top right side of the sheet feeder when you are facing the front of the printer.)



**NOTE:** Never force the paper bin. Always press the release button to open the bin.

---

6. Open the top cover on the printer.

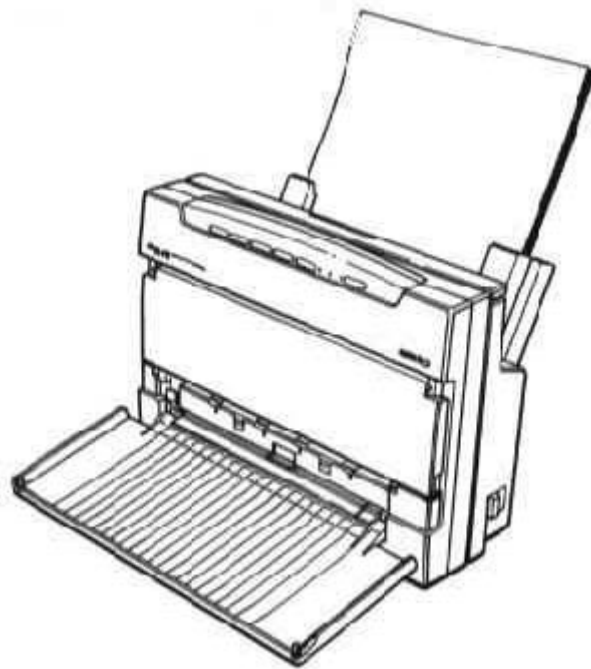

7. Turn on the printer, and start your print operation.



**NOTE:** Always remove the sheet feeder before transporting the printer.

---

◀ BACK

NEXT ▶

▶ BACK TO START

## ***Battery Pack***

The Canon NB-150 rechargeable battery pack allows you to operate the printer where AC power is not available.



### ***Cautions***

Follow these guidelines to avoid damage to your printer or battery pack, and harm to you or others:

- Before using a new battery pack, charge it as described later in this chapter.
- Use only the Canon NB-150 rechargeable battery pack with the Bubble Jet Printer BJ-10sx.
- Do not attempt to disassemble a battery pack.
- Follow local regulations when disposing of a used battery pack.
- Do not dispose of battery pack where it may come in contact with fire.
- Keep foreign objects out of the battery compartment.



- Recharge the battery pack only when it is fully discharged. Charging it before it is fully discharged reduces the battery capacity
- Avoid touching the terminals on the battery pack.
- Remove the battery pack when you are storing the printer.

## ***Installing the Battery Pack***

Make sure you are facing the back of the printer, and follow these steps to install the battery pack:

1. Grasp the front of the printer with one hand and position the printer stand with your other hand.



2. Holding the printer securely, press the two recesses on the back of the printer to release the tabs that hold the battery compartment cover in place. Lift the battery compartment cover off the printer case

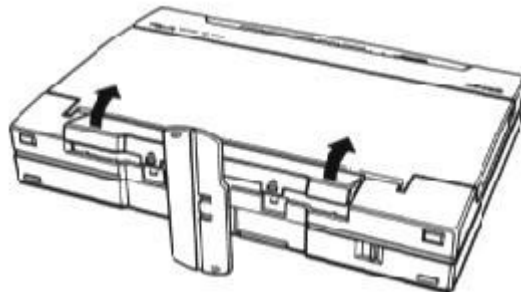



3. Hold the printer with one hand and the battery pack with the other hand. Make sure the writing on the battery is up and the terminals are down. The terminal end of the battery has silver arrow showing the direction in which you insert the battery.
4. Insert the battery pack in to the compartment -- terminal end first. (When installed correctly, the writing on the battery pack is upside-down if you're facing the back of the printer.)

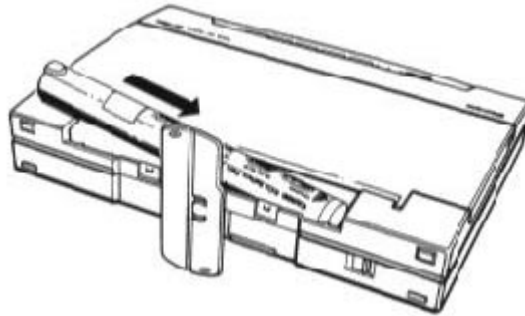

5. Replace the battery compartment cover.
6. Rotate the printer stand back to its original position.

## ***Charging the Battery Pack***

---

**NOTE:** Always charge a new battery pack. A new battery is not charged.



---

It takes approximately 10 hours to charge a new battery or a fully discharged battery. When you are charging a battery pack, the printer cannot print.

With a fully charged battery pack, you may be able to print up to 40 pages without the use of AC power. The actual printing time depends on the complexity of the data you are printing.

To charge a battery pack, follow these steps:

1. Make sure the printer is turned off.
2. Turn on the battery switch.

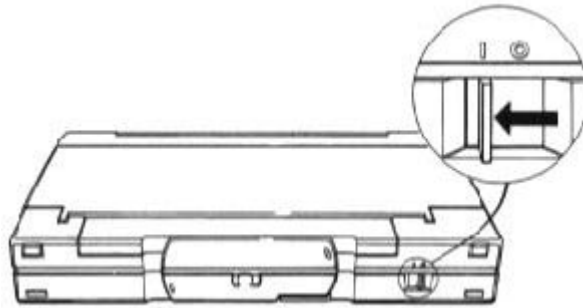

3. Press and hold the **ON LINE** button, and press the **POWER** button. When the printer beeps, release the **POWER** button. When it beeps again, release the **ON LINE** button. The **POWER** light blinks.

The **POWER** light continues to blink while the battery is charging (about 10 hours). When the battery is fully charged, the printer automatically turns off.

### ***Using the Battery Pack***

To print using battery power, follow these steps:

1. Make sure the AC adapter is disconnected. (When the AC adapter is connected, the printer will always use AC power.)



2. Turn on the battery switch.

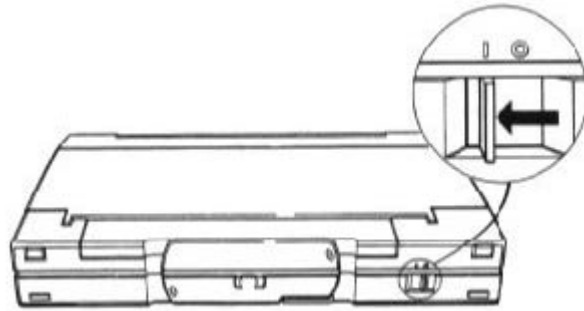

3. Turn on the printer.

If you are using the battery pack and the printer does not receive any data for 15 minutes, the printer automatically turns off to save battery power.



---

**NOTE:** When you are not using battery power, turn off the battery switch.

---

### ***Printing with a low battery***

When you are using the battery pack and the POWER light blinks, the battery is low. If you are in the process of printing, follow these steps:

1. Connect the AC adapter to the printer and the wall outlet.
2. Press **ON LINE** to continue printing.
3. When you are through printing, recharge the battery as described in the previous section Charging a Battery Pack.



If an AC outlet is not available, you can use the remaining battery power for limited printing. Press **ON LINE** to continue printing. Each time you press **ON LINE**, the printer will print several lines until the battery pack is fully discharged.

### ***Low battery error***

When the battery pack becomes fully discharge, a low battery error occurs. The **POWER** light starts to blink, the **ON LINE** light goes out, and the **ERROR** light goes on. In this case, you must recharge the battery. If you are in the process of printing, the only way to continue is to connect the AC adapter.

Recharge the battery as described in the previous section, *Charging a Battery Pack*.



---

**CAUTION:** Recharge the battery pack only when it is fully discharged. Charging the battery before it is fully discharged reduces the battery capacity.

---

## ***Removing the Battery Pack***



---

**NOTE:** Make sure you have completed your current print job as removing the battery pack erases all data in the printer's memory.

---

Follow these steps to remove the battery pack:

1. Make sure the battery switch is turned off.
2. Lift the printer and rotate the printer stand.
3. Hold the printer securely, and remove the battery compartment cover.

4. Hold the printer with one hand and grasp the tab on the battery pack with the other hand. Pull out the battery pack.

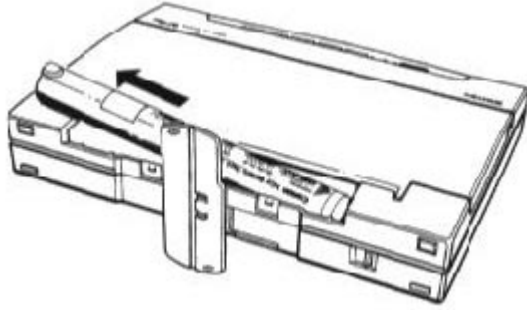

5. Replace the battery compartment cover.
6. Rotate the printer stand back to its original position.



# Appendix A

## Printer Specifications

---

This appendix lists the specifications of your printer.

### **Printer Method**

Bubble jet ink on-demand

### **Printing Speed**

110 characters per second (cps) in 10 characters per inch (cpi) in both HQ and economy modes.

### **Printing Direction**

Bi-directional in text; Unidirectional in graphics

### **Printing Width**

Maximum 8 inches (203 mm)

### **Line Feed Speed**

180 ms/line at 1/6-inch line

### **Resident Printer Control Modes**

BJ-10e      IBM Proprinter X24E emulation or Canon Bubble Jet  
mode:      Printer BJ-130e emulation

Epson LQ    Epson LQ-510 emulation  
mode:

### **Line Feed Pitch:**

BJ-10e      1/6, 1/8, n/60, n/72, n/180, n/216, and n/360 inch (n:  
mode:      programmable)

Epson LQ    1/6, 1/8, n/60, n/180, and n/360 inch (n: programmable)  
mode:

◀ BACK

NEXT ▶

▶ BACK TO START

## Printing Characters

### Font:

IBM Proprinter X24E emulation	Prestige (12 cpi) and Courier (other than 12 cpi)
BJ-130e emulation	Courier
Epson LQ-510 emulation	Roman, Sans serif, and Draft

### Pitch:

BJ-10e mode	10, 12, and 17 cpi and PS
Epson LQ mode	10, 12, 15, 17, and 20 cpi and PS
Cell composition:	36 (h) x 48 (v) dot matrix in HQ mode 18 out of 36 (h) x 48 (v) dot matrix in economy mode

### Character set:

BJ-10e mode	IBM Character Set 1, 2, and 3 (code page 437 and 850)
Epson LQ mode	Italics character set and Graphics character set

## Maximum Number of Characters per Line

### BJ-10e mode

Mode	Pitch	Characters per line
10 cpi	10 cpi	80 cpl
10 cpi double-wide	5 cpi	40 cpl
10 cpi condensed	17 cpi	136 cpl
10 cpi condensed, double-wide	8.5 cpi	68 cpl
12 cpi	12 cpi	96 cpl
12 cpi double-wide	6 cpi	48 cpl
Proportional spacing	PS	Varies



## Epson LQ mode

<b>Mode</b>	<b>Pitch</b>	<b>Characters per line</b>
10 cpi	10 cpi	80 cpl
10 cpi double-wide	5 cpi	40 cpl
10 cpi condensed	17 cpi	136 cpl
10 cpi condensed, double-wide	8.5 cpi	68 cpl
12 cpi	12 cpi	96 cpl
12 cpi double-wide	6 cpi	48 cpl
12 cpi condensed	20 cpi	160 cpl
12 cpi condensed, double-wide	10 cpi	80 cpl
15 cpi	15 cpi	120 cpl
15 cpi double-wide	7.5 cpi	60 cpl
Proportional spacing	PS	Varies

## Graphic Image Print

Data format: Vertical 8, 24, and/or 48-dot format

Resolution: Horizontal 60, 120, 180, 240, or 360 dots per inch (dpi)

## Buffer

BJ-10e mode

Input buffer: 37 KB (or 3 KB)

Download buffer: 0 KB (or 34 KB)

Epson LQ mode

Input buffer: 10 KB

Download buffer: 18 KB





Printing Area  
Paper

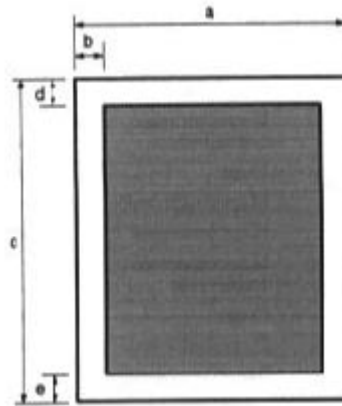

Horizontal

- a 7.2 to 8.5 in (182 to 216 mm)
- b 0.13 in (3.4 mm) -- A4 size paper  
0.25 in (6.4 mm) -- Letter-size paper

Vertical

- c 10.1 to 14.0 in (257 to 356 mm)
- d 0.33 in (8.5 mm)
- e 0.5 in (12.7 mm)

Envelopes

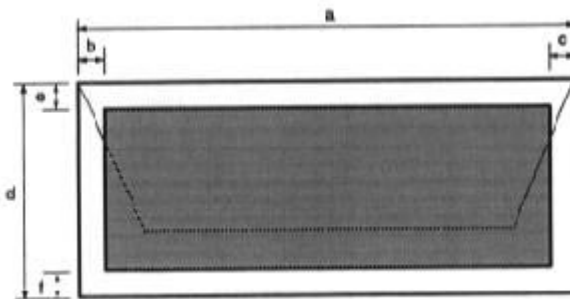

### Horizontal

a	9.5 in (240 mm)
b	0.25 in (6.4 mm)
c	0.25 in (6.4 mm)

### Vertical

d	4.1 in (104 mm)
e	0.67 in (17 mm)
f	1.0 in (25.4 mm)

## Paper Size

Letter:	8.5 by 11 inches
Legal:	8.5 by 14 inches
A4:	210 by 297 mm
Envelope:	9.5 by 4.125 inches (Commercial number 10)

## Paper Type

Plain paper  
Envelopes (Commercial number 10)  
Transparency film (Canon #Q07-0001-M1)

## Paper Weight

17 to 24 lb (64 to 90 g/m<sup>2</sup>) from the top feed  
17 to 28 lb (64 to 105 g/m<sup>2</sup>) from the bottom slot

## Paper Thickness

Under 0.008 inch (0.2 mm)

## Interface

8-bit parallel

## Ink Cartridge

Type:	BC-01 (single cartridge ink supply)
Print head:	64 bubble jet nozzles
Ink color:	Black
Number of characters printed:	Approx. 700,000 characters/cartridge in HQ mode Approx. 1,400,000 characters/cartridge in economy mode
Ink amount:	Approx. 0.9 oz (28g)

## Acoustic Noise Level

Approx. 45 dB(A)



### **Operating Environment**

Temperature: 41F to 95F (5C to 35C)  
10% to 90% RH (no condensation)

### **Storing Environment**

Temperature: 32F to 95F (0C to 35C)  
Humidity 5% to 95% RH (no condensation)

### **Power Supply**

AC adapter or optional Canon NB-150 battery pack

### **Power Source**

USA/Canada AC 120V, 60Hz 30W

### **Physical Dimensions**

Size: 12.2 (W) x 8.7 (D) x 1.9 (H) inches  
(310 x 221.3 x 48.5 mm)

Weight: Approx. 3.7 lbs (1.7 kg) -- excluding AC adapter, optional battery pack, and optional sheet feeder

## ***Options Specifications***

### ***Sheet Feeder***

#### **Paper Handling**

Capacity:  
ASF-6410 30 sheets of 17 lb (64 g/m<sup>2</sup>) paper  
ASF-6420 50 sheets of 17 lb (64 g/m<sup>2</sup>) paper  
Paper sizes: Letter, A4  
Paper weight: 17 to 24 lbs (64 to 90 g/m<sup>2</sup>)

#### **Operating Environment**

Temperature: 59F to 86F (15C to 30C)  
Humidity: 10% to 80% RH (no condensation)

#### **Storing Environment**

Temperature: 22F to 140F (-30C to 60C)  
Humidity 10% to 90% RH (no condensation)

### **Physical Dimensions**

ASF-6410

Size: 12.2 x 8.5 x 2.1 inches  
(309.5 x 216.0 x 54.5 mm)

Weight: Approx. 1.8 lbs (0.8 kg)

ASF-6420

Size: 12.2 x 8.6 x 2.3 inches  
(310.0 x 217.5 x 57.5 mm)

Weight: Approx. 2.9 lbs (1.3 kg)

## ***Battery Pack***

### **Model**

Canon NB-150

### **Electrical**

Voltage: DC 6V

Capacity: 1300 mAh

Life: Approx. 40 pages per charge  
(continuous use)

### **Physical Dimensions**

Size: 8.4 x 1.0 inches (213 x 25 mm)

Weight: Approx. 9.9 oz (280g)

### **Storing Environment**

Temperature: 14F to 140F (-10C to 40C)

Humidity: 10% to 90% RH (no condensation)



# Appendix B

## Interface Specifications

---

This printer is equipped with the standard Centronics-type parallel interface for data communications. You use this interface to connect the printer to a computer. This interface is the most widely used interface on personal computers and does not require setup commands or special configurations on either the computer or printer. The printer's parallel interface connector is a standard 36-pin, Amphenol type with two metal-wire retaining clips.

The parallel interface sends 8 bits (one byte) of data at one time and is transistor-transistor-logic (TTL) compatible.

The interface cable must be constructed of American Wire Gauge (AWG) No. 28 or larger. The maximum length of the twisted-pair, shielded cable must be approximately 6.5 feet (2.0 m).

### **Interface type**

Standard Centronics-type

### **Data transmission**

8-bit parallel interface (compatible with IBM and other personal computers)

### **Signal voltage levels**

Low: 0.0V to +0.8V

High: +2.4V to +5.0V

### **Interface cable**

Twisted-pair, shielded cable

AWG28 or larger

Up to 6.6 feet (2.0 m)

### **Interface connectors**

Amphenol 57-40360 (or equivalent) at printer side

Amphenol 57-30360 (or equivalent) at cable side



### Input circuit

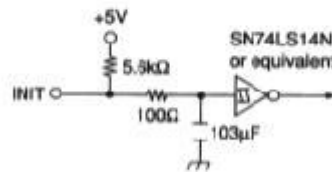
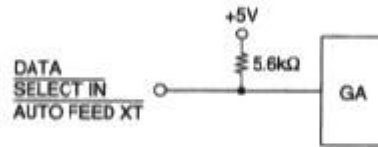
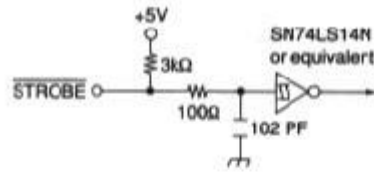

### Output circuit



◀ BACK

NEXT ▶

▶ BACK TO START

## Pin assignments

The following table lists the signals and input/output status of the pin assignments used for parallel communication.

<u>No.</u>	<u>Signal</u>	<u>I/O</u>	<u>No.</u>	<u>Signal</u>	<u>I/O</u>
1	STROBE	IN	19	STROBE-OUT <sup>1</sup>	
2	DATA 1	IN	20	DATA 1-RET	
3	DATA 2	IN	21	DATA 2-RET	
4	DATA 3	IN	22	DATA 3-RET	
5	DATA 4	IN	23	DATA 4-RET	
6	DATA 5	IN	24	DATA 5-RET	
7	DATA 6	IN	25	DATA 6-RET	
8	DATA 7	IN	26	DATA 7-RET	
9	DATA 8	IN	27	DATA 8-RET	
10	ACKNLG	OUT	28	ACKNLG-RET	
11	BUSY	OUT	29	BUSY-RET	
12	PAPER END	OUT	30	PAPER END-RET	
13	SELECT	OUT	31	INIT	IN
14	AUTO FEED XT <sup>2</sup>		32	ERROR	OUT
15	NO CONNECTION		33	GND	
16	GND		34	NO CONNECTION	
17	FG		35	+5.0V <sup>3</sup>	
18	NO CONNECTION		36	SELECT IN <sup>2</sup>	

<sup>1</sup>All-RETs are connected to GND.

<sup>2</sup>These signals are valid only in Epson LQ printer control mode.

<sup>3</sup>The level is raised to +5.0V at 5.6k.

Each signal is defined as follows:

### STROBE

When the printer receives the STROBE low pulse with a width greater than one second from the computer, it reads the data from the interface and sets the BUSY line high.



## **DATA**

These signals are the 8 bits of parallel data sent from the computer. A high level indicates a logical 1; a low level indicates a logical 0. The printer reads the DATA lines when it receives a STROBE pulse.

## **ACKNLG**

The ACKNLG pulse tells the computer that the printer has read the data from the previous STROBE pulse. An ACKNLG pulse is also generated when the printer is powered on, or at the completion of the printer initialization by an INIT signal requested from the computer.

## **BUSY**

When the printer sets BUSY high, it cannot receive data. The BUSY line goes high in response to a STROBE pulse. This line remains high until the data is read. BUSY is also high under the following conditions:

- The receive buffer is full of data.
- The printer receives an INIT signal.
- You press the ON LINE button to set the printer off-line.
- A printer error condition, such as out-of-paper, occurs.

## **PAPER END**

The printer sets PAPER END high when it is out of paper or when a paper jam occurs. PAPER END remains high until you load paper or clear the jam and press the ON LINE button.

## **SELECT**

When the printer is ready, it sets the SELECT line high. The SELECT line goes low when:

- You press the ON LINE button to set the printer off-line.
- An error condition, such as out-of-paper, occurs.
- The printer receives the Printer Deselect command. It ignores all incoming data except DC1, which returns it to a selected state.



### **AUTO FEED XT**

When this signal is low, the printer automatically feeds the paper one line when it receives a carriage return (CR) control code. This signal is valid only in Epson LQ mode.

### **INIT**

INIT from the system resets the printer to its initial power-on state. The BUSY line goes high, and any received data is printed. When INIT goes low, the printer resets to the power-on default state.

### **ERROR**

The printer sets the ERROR line low if it detects an error, such as out-of-paper condition.

### **SELECT IN**

When this signal is high, the DC1 and DC3 control codes are valid; otherwise, they are invalid. This signal is valid only in Epson LQ mode.

## ***Timing Chart***

The parallel interface transfers data in one direction only: from the computer to your printer. The data path is 8 bits wide. The printer and computer synchronize data transfer with the interface signals, STROBE, ACKNLG, and BUSY.

When the computer is ready to send a byte of data to the printer, it puts the byte of data on the data lines (DATA 1 through DATA 8). Then the computer sends a STROBE pulse to the printer. The printer responds with a BUSY signal.

When the printer receives the data, it pulses the ACKNLG line. This signals the computer that the printer has read the byte of data into printer memory. If the printer's buffer is not full and it can receive more data, it removes the BUSY signal.

The timing charts that follow illustrate the data and handshake line during transfer of one data byte to the computer. DATA 1 through DATA 8 and the STROBE line are driven by the computer; the ACKNLG line is driven by the printer.



### Timing Chart in BJ-10e mode

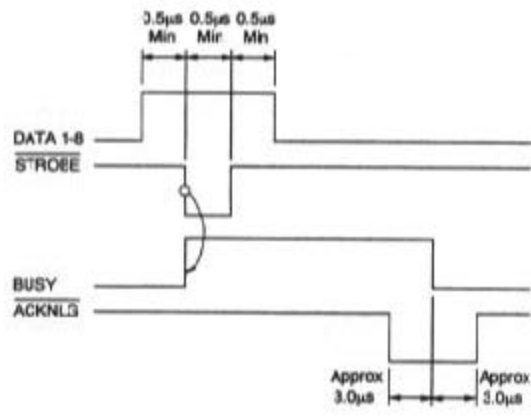

### Timing Chart in Epson LQ mode

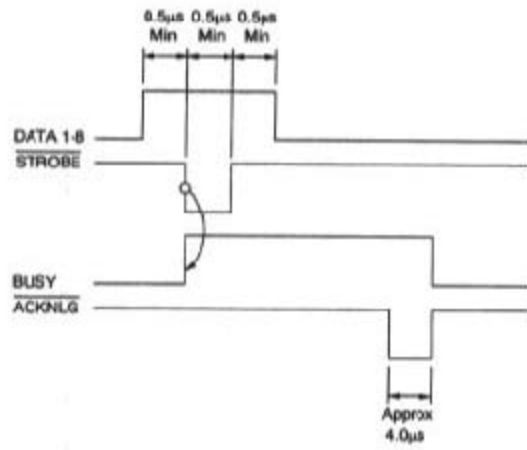

# Appendix C

## Printer Mode Command Summaries and Character Sets

---

This appendix lists the control codes and ESCape sequences you can use in BJ-10e mode and Epson LQ mode, and shows the character sets available in each mode. For a complete description of these programming commands, you can order the Canon Bubble Jet Printer BJ-10sx Programmer's Manual. Call the Canon help desk at 1-800-423-2366 to order this manual

Control codes and ESCape sequences tell the printer how to print a job. You send commands to the printer in one of two ways:

- You can use your application software to automatically embed certain commands (such as bold, underline, or indent) within a document. When the document prints, the embedded command control the way the printer produces the printed page. Refer to your application software manual for instructions on sending commands.
- You can send specific commands directly to the printer, using either a BASIC programming statement or a printer command option in your software.

### ***BJ-10e Command Summary***

You can use the control codes and ESCape sequences listed in the following table when the printer is in BJ-10e mode; that is, when DIP switch 11 is set to OFF. In this mode, the printer can emulate either the IBM Proprinter X24E (DIP switch 10 OFF) or the Canon Bubble Jet Printer BJ-130e (DIP switch 10 ON). Differences between IBM Proprinter X24E emulation and Bubble Jet Printer BJ-130e emulation are described following the command summary tables.





---

**NOTE:** Because of hardware differences, the reverse feed code (ESC J) is not supported by your printer. Also, the styles of block graphics characters at 12 cpi are different from those used by the IBM Proprinter X24E.

---

## ***Basic Control Codes***

<b><u>Function</u></b>	<b><u>ASCII</u></b>	<b><u>Decimal</u></b>	<b><u>Hexadecimal</u></b>
End command	NUL	0	00
Sound beeper	BEL	7	07
Backspace one character	BS	8	08
Horizontal tab control; move to next tab	HT	9	09
Perform line feed	LF	10	0A
Vertical tab control; move to next tab	VT	11	0B
Perform form feed	FF	12	0C
Perform carriage return	CR	13	0D
Set double-wide mode by line	SO	14	0E
Set condensed mode (17 cpi); cancelled by DC2	SI	15	0F
Set printer on-line	DC1	17	11
Set 10 cpi mode	DC2	18	12
Set printer off-line	DC3	19	13
Cancel double-wide mode	DC4	20	14
Cancel data	CAN	24	18
Insert space	SP	32	20



## ESCape Sequence Codes

<u>Function</u>	<u>ASCII</u>	<u>Decimal</u>	<u>Hexadecimal</u>
Set/cancel underscore mode n Setting 0 End underscore 1 Start under score	ESC - n	27 45 n	1B 2D n
Set 1/8-inch line spacing (8 lpi)	ESC 0	27 48	1B 30
Set 7/72-inch line spacing (7/72 inch per line)	ESC 1	27 49	1B 31
Enable line spacing set by ESC A	ESC 2	27 50	1B 32
Set graphics line spacing in n/180-inch increments; n = 1 to 85	ESC 3 n	27 51 n	1B 33 n
Set top of form	ESC 4	27 52	1B 34
Set/cancel automatic LF n Setting 0 End automatic line feed 1 Start automatic line feed	ESC 5 n	27 53 n	1B 35 n
Select IBM Character Set 2	ESC 6	27 54	1B 36
Select IBM Character Set 1	ESC 7	27 55	1B 37
Set 12-cpi, Prestige mode	ESC :	27 58	1B 3A
Download 24-dot, font image	ESC = n1 n2 #	27 61 n1 n2 35	1B 3D n1 n2 23
Download 48-dot, font image	ESC = n1 n2 %	27 61 n1 n2 37	1B 3D n1 n2 25
Set text line spacing to n/72 inch per line; n = 1 to 255	ESC A n	27 65 n	1B 41 n
Set vertical tab; n1 ... n64 = line numbers for tab stops	ESC B n1 ... n64 NUL	27 66 n1 ... n64 0	1B 42 n1 ... n64 0

<b><u>Function</u></b>	<b><u>ASCII</u></b>	<b><u>Decimal</u></b>	<b><u>Hexadecimal</u></b>
Set page length in lines; n = 1 to 255	ESC C n	27 67 n	1B 43 n
Set page length in inches; n = 1 to 14	ESC C NUL n	27 67 0 n	1B 43 00 n
Set horizontal tabs; n1 ... n28 = columns for tab stops	ESC D n1...n28 NUL	27 68 n1...n28 0	1B 44 n1...n28 00
Set emphasized mode to start printing in twice the normal dot density	ESC E	27 69	1B 45
Cancel emphasized mode set by ESC E	ESC F	27 70	1B 46
Set double-strike mode	ESC G	27 71	1B 47
Cancel double-strike mode set by ESC G	ESC H	27 72	1B 48
Select font style	ESC I n	27 73 n	1B 49 n
Perform graphics line spacing; n = 0 to 255	ESC J n	27 74 n	1B 4A n
Set single-density image graphics	ESC K n1 n2	27 75 n1 n2	1B 4B n1 n2
Set double-density image graphics	ESC L n1 n2	27 76 n1 n2	1B 4C n1 n2
Set perforation skip; n = 0 to 255 lines	ESC N n	27 78 n	1B 4E n
Cancel perforation skip	ESC O	27 79	1B 4F
Set/cancel proportional spacing mode n Setting 0 End proportional spacing 1 Start proportional spacing	ESC P n	27 80 n	1B 50 n
Deselect printer	ESC Q n	27 81 n	1B 51 n
Set all tabs to default settings	ESC R	27 82	1B 52

<u>Function</u>	<u>ASCII</u>	<u>Decimal</u>	<u>Hexadecimal</u>
Set super/subscript mode n Setting 0 Select superscript mode 1 Select subscript mode	ESC S n	27 83 n	1B 53 n
Cancel super/subscript mode set by ESC S	ESC T	27 84	1B 54
Select printer direction	ESC U n	27 85 n	1B 55 n
Set/cancel double-wide mode n Setting 0 Cancel double-wide mode 1 Start double-wide mode	ESC W n	27 87 n	1B 57 n
Set horizontal margins; n and m = 0 to 255	ESC X n m	27 88 n m	1B 58 n m
Set double-density image graphics mode	ESC Y n1 n2	27 89 n1 n2	1B 59 n1 n2
Set quadruple-density image graphics mode	ESC Z n1 n2	27 90 n1 n2	1B 5A n1 n2
Set/cancel presentation highlight (double-high mode)	ESC [ @ n1 n2 m1 m2 m3 m4	27 91 64 n1 n2 m1 m2 m3 m4	1B 5B 40 n1 n2 m1 m2 m3 m4
Select global font	ESC [ I	27 91 73	1B 5B 49
Set initial condition	ESC [ K n1 n2	27 91 75 n1 n2	1B 5B 4B n1 n2
Set code page	ESC [ T n1 n2	27 91 84 n1 n2	1B 5B 54 n1 n2
Change graphics line spacing	ESC [ \ n1 n2	27 91 92 n1 n2	1B 5B 5C n1 n2
Select high resolution graphics mode	ESC [ g n1 n2	27 91 103 n1 n2	1B 5B 67 n1 n2
Print continuously from All Characters Chart	ESC \ n1 n2	27 92 n1 n2	1B 5C n1 n2



<u>Function</u>	<u>ASCII</u>	<u>Decimal</u>	<u>Hexadecimal</u>
Print single character from All Characters Chart	ESC ^	27 94	1B 5E
Set/cancel overscore mode n Setting 0 Cancel overscore mode 1 Set overscore mode	ESC _ n	27 95 n	1B 5F n
Relative move inline to the right	ESC d n1 n2	27 100 n1 n2	1B 64 n1 n2
Set printer off-line	ESC j	27 106	1B 6A

### ***Alternate Graphics Mode codes***

Select graphics mode (AGM)	ESC * m n1 n2	27 42 m n1 n2	1B 2A m n1 n2
Set graphics line spacing (AGM); n = 0 to 255	ESC 3 n	27 51 n	1B 33 n
Set text line spacing (AGM); n = 1 to 85	ESC A n	27 65 n	1B 41 n
Perform graphics line spacing (AGM); n = 0 to 255	ESC J n	27 74 n	1B 4A n

## ***Miscellaneous Control Codes***

<u>Function</u>	<u>ASCII</u>	<u>Decimal</u>	<u>Hexadecimal</u>
Set 360 dpi graphics	FS C B	28 67 66	1C 43 42
Set/perform 1/360-inch graphics line spacing	FS C J n m	28 67 74 n m	1C 43 4A n m

# ***ESCape Sequence Differences***

The following ESCape sequences cause different operations to be performed in each emulation, IBM Proprinter X24E and Canon Bubble Jet Printer BJ-130e.

## **ESCape**

<b><u>sequence</u></b>	<b><u>Emulation</u></b>	<b><u>Function</u></b>
ESC :	X24E	Set 12 cpi, Prestige mode
	BJ-130e	Set 12 cpi, Courier mode
ESC =	X24E	Download 24-dot, font image
	BJ-130e	Download 48-dot, font image
ESC P	X24E	Draft proportional spacing not available
	BJ-130e	Draft proportional spacing available
ESC Q	X24E	n = 35 or 36
	BJ-10e	n = 35 or 37
ESC [ @	X24E	Shading and reverse modes are not available
	BJ-130e	Shading and reverse modes can be set with m2
ESC [ K	X24E	m1 is set to 0 if it is not defined
	BJ-130e	m1 is ignored if it is not defined

The printer supports the following codes in BJ-130e emulation only:

<b><u>Code</u></b>	<b><u>Function</u></b>
ESC [ I	Select global font
FS C B	Set high resolution graphics
FS C J	Set graphics line spacing



## BJ-10e Character Sets

In BJ-10e mode, your printer supports two IBM code pages: USA code page 437 and Multilingual code page 850. Each code page has three character sets: Character Set 1, Character Set 2, and All Characters Chart.

You select the code page by setting DIP switch 9 -- OFF for code page 437, ON for 850. You select the character set by setting DIP switch 5 -- OFF for Character Set 1, ON for Character Set 2.

Each code page corresponds to an All Characters Chart. For the All Characters Chart, there are no control codes except for the space codes at ASCII 32. All other ASCII characters are printable. The All Characters Chart is selected by the ESC ^ or the ESC \ code.

Character Set 1 has control codes in two places: one between ASCII 0 and ASCII 32 and the other between ASCII 128 and ASCII 159. Character Set 2 has control codes only between ASCII 0 and 32. All other ASCII characters are printable.

The three character sets for each code page are shown on following pages.



---

**NOTE:** A control code is an unprintable character that the printer uses for printer operations, such as line spacing or carriage return.

---

◀ BACK

NEXT ▶

▶ BACK TO START

**USA Code  
Page 437**

**Character Set 1**

**USA Code  
Page 437**

**Character Set 2**

Hex No.	0	1	2	3	4	5	6	7	8	9	A	B	C	D	E	F	Hex No.
0	NUL	SP	D	@	P	B	C	E	A	L	A	Q	W				0000
1	DC1	1	A	Q	A	U	W	I	U	Y	B	S					0001
2	DC2	2	B	R	D	F	R	G	V	T	Z						0002
3	3	3	C	S	E	S	O	U	I	J	K	X					0003
4	DC4	4	D	Y	4	T	A	O	A	-	N	Z	/				0100
5	5	5	E	U	5	E	U	5	E	U	5	E	U				0101
6	6	6	F	V	6	F	V	6	F	V	6	F	V				0110
7	BEL	7	G	W	7	G	W	7	G	W	7	G	W				0111
8	BS CAN	(	B	H	X	R	K	6	y	Δ	Δ	Δ	Δ	Δ	Δ	Δ	1000
9	HT	)	D	I	V	I	Y	8	O	~	~	~	~	~	~	~	1001
A	LF	^	J	Z	J	Z	J	Z	J	Z	J	Z	J	Z	J	Z	1010
B	VT ESC	-	K	I	K	I	K	I	K	I	K	I	K	I	K	I	1011
C	FF FS	~	L	I	I	I	I	I	I	I	I	I	I	I	I	I	1100
D	CR	~	M	J	M	J	M	J	M	J	M	J	M	J	M	J	1101
E	SO	~	N	A	N	A	N	A	N	A	N	A	N	A	N	A	1110
F	SI	/	O	-	O	-	O	-	O	-	O	-	O	-	O	-	1111
0000	0001	0010	0011	0100	0101	0110	0111	1000	1001	1010	1011	1100	1101	1110	1111	Binary No.	

Hex No.	0	1	2	3	4	5	6	7	8	9	A	B	C	D	E	F	Hex No.
0	NUL	SP	D	@	P	B	C	E	A	L	A	Q	W				0000
1	DC1	1	A	Q	A	U	W	I	U	Y	B	S					0001
2	DC2	2	B	R	D	F	R	G	V	T	Z						0002
3	3	3	C	S	E	S	O	U	I	J	K	X					0003
4	DC4	4	D	Y	4	T	A	O	A	-	N	Z	/				0100
5	5	5	E	U	5	E	U	5	E	U	5	E	U				0101
6	6	6	F	V	6	F	V	6	F	V	6	F	V				0110
7	BEL	7	G	W	7	G	W	7	G	W	7	G	W				0111
8	BS CAN	(	B	H	X	R	K	6	y	Δ	Δ	Δ	Δ	Δ	Δ	Δ	1000
9	HT	)	D	I	V	I	Y	8	O	~	~	~	~	~	~	~	1001
A	LF	^	J	Z	J	Z	J	Z	J	Z	J	Z	J	Z	J	Z	1010
B	VT ESC	-	K	I	K	I	K	I	K	I	K	I	K	I	K	I	1011
C	FF FS	~	L	I	I	I	I	I	I	I	I	I	I	I	I	I	1100
D	CR	~	M	J	M	J	M	J	M	J	M	J	M	J	M	J	1101
E	SO	~	N	A	N	A	N	A	N	A	N	A	N	A	N	A	1110
F	SI	/	O	-	O	-	O	-	O	-	O	-	O	-	O	-	1111
0000	0001	0010	0011	0100	0101	0110	0111	1000	1001	1010	1011	1100	1101	1110	1111	Binary No.	

**USA Code  
Page 437**

**All Characters  
Chart**

**Multilingual  
Code Page  
850**

**Character Set 1**

Hex No.	0	1	2	3	4	5	6	7	8	9	A	B	C	D	E	F
0	SP	SP	0	0	P	P	Ç	E	È	É	À	Á	Â	Ã	Ä	Å
1	1	2	3	4	5	6	7	8	9	0	1	2	3	4	5	6
2	1	2	3	4	5	6	7	8	9	0	1	2	3	4	5	6
3	1	2	3	4	5	6	7	8	9	0	1	2	3	4	5	6
4	1	2	3	4	5	6	7	8	9	0	1	2	3	4	5	6
5	1	2	3	4	5	6	7	8	9	0	1	2	3	4	5	6
6	1	2	3	4	5	6	7	8	9	0	1	2	3	4	5	6
7	1	2	3	4	5	6	7	8	9	0	1	2	3	4	5	6
8	1	2	3	4	5	6	7	8	9	0	1	2	3	4	5	6
9	1	2	3	4	5	6	7	8	9	0	1	2	3	4	5	6
A	1	2	3	4	5	6	7	8	9	0	1	2	3	4	5	6
B	1	2	3	4	5	6	7	8	9	0	1	2	3	4	5	6
C	1	2	3	4	5	6	7	8	9	0	1	2	3	4	5	6
D	1	2	3	4	5	6	7	8	9	0	1	2	3	4	5	6
E	1	2	3	4	5	6	7	8	9	0	1	2	3	4	5	6
F	1	2	3	4	5	6	7	8	9	0	1	2	3	4	5	6
0000	0001	0010	0011	0100	0101	0110	0111	1000	1001	1010	1011	1100	1101	1110	1111	Binary No.

Hex No.	0	1	2	3	4	5	6	7	8	9	A	B	C	D	E	F
0	NUL	SP	0	0	P	P	RUL	À	Á	Â	Ã	Ä	Å	Æ	Ç	Ð
1	DC1	1	2	3	4	5	6	7	8	9	0	1	2	3	4	5
2	DC2	1	2	3	4	5	6	7	8	9	0	1	2	3	4	5
3	1	2	3	4	5	6	7	8	9	0	1	2	3	4	5	6
4	1	2	3	4	5	6	7	8	9	0	1	2	3	4	5	6
5	1	2	3	4	5	6	7	8	9	0	1	2	3	4	5	6
6	1	2	3	4	5	6	7	8	9	0	1	2	3	4	5	6
7	1	2	3	4	5	6	7	8	9	0	1	2	3	4	5	6
8	1	2	3	4	5	6	7	8	9	0	1	2	3	4	5	6
9	1	2	3	4	5	6	7	8	9	0	1	2	3	4	5	6
A	1	2	3	4	5	6	7	8	9	0	1	2	3	4	5	6
B	1	2	3	4	5	6	7	8	9	0	1	2	3	4	5	6
C	1	2	3	4	5	6	7	8	9	0	1	2	3	4	5	6
D	1	2	3	4	5	6	7	8	9	0	1	2	3	4	5	6
E	1	2	3	4	5	6	7	8	9	0	1	2	3	4	5	6
F	1	2	3	4	5	6	7	8	9	0	1	2	3	4	5	6
0000	0001	0010	0011	0100	0101	0110	0111	1000	1001	1010	1011	1100	1101	1110	1111	Binary No.

**Multilingual  
Code Page  
850**

**Character Set 2**

**Multilingual  
Code Page  
850**

**All Characters  
Chart**

Hex Name	0	1	2	3	4	5	6	7	8	9	A	B	C	D	E	F		
0	NUL	SP	0	1	2	3	4	5	6	7	8	9	A	B	C	D	E	F
1	DC1	1	2	3	4	5	6	7	8	9	A	B	C	D	E	F	0001	
2	DC2	2	3	4	5	6	7	8	9	A	B	C	D	E	F	0002	0010	
3	W	3	4	5	6	7	8	9	A	B	C	D	E	F	0003	0011	0100	
4	DC4	4	5	6	7	8	9	A	B	C	D	E	F	0004	0012	0101	1000	
5	+	5	6	7	8	9	A	B	C	D	E	F	0005	0013	0102	1001	1100	
6	+	6	7	8	9	A	B	C	D	E	F	0006	0014	0103	0104	1002	1101	
7	BEL	7	8	9	A	B	C	D	E	F	0007	0015	0104	0105	1003	1102	1110	
8	BS	8	9	A	B	C	D	E	F	0008	0016	0105	0106	1004	1103	1111	1000	
9	CAN	9	A	B	C	D	E	F	0009	0017	0106	0107	1005	1104	1112	1001	1000	
A	HT	A	B	C	D	E	F	000A	0018	0107	0108	1006	1105	1113	1002	1001	1001	
B	LF	B	C	D	E	F	000B	0019	0108	0109	1007	1106	1114	1003	1002	1002	1010	
C	VT	C	D	E	F	000C	0020	0109	0110	1008	1107	1115	1004	1003	1003	1003	1011	
D	ESC	D	E	F	000D	0021	0110	0111	1009	1108	1116	1005	1004	1004	1004	1004	1012	
E	FF	E	F	000E	0022	0111	0112	1010	1109	1117	1006	1005	1005	1005	1005	1005	1013	
F	CR	F	000F	0023	0112	0113	1011	1110	1118	1007	1006	1006	1006	1006	1006	1006	1014	
0000	0001	0010	0011	0100	0101	0110	0111	1000	1001	1010	1011	1100	1101	1110	1111	1000	1001	

Hex Name	0	1	2	3	4	5	6	7	8	9	A	B	C	D	E	F		
0	NUL	SP	0	1	2	3	4	5	6	7	8	9	A	B	C	D	E	F
1	DC1	1	2	3	4	5	6	7	8	9	A	B	C	D	E	F	0001	
2	DC2	2	3	4	5	6	7	8	9	A	B	C	D	E	F	0002	0010	
3	W	3	4	5	6	7	8	9	A	B	C	D	E	F	0003	0011	0100	
4	DC4	4	5	6	7	8	9	A	B	C	D	E	F	0004	0012	0101	1000	
5	+	5	6	7	8	9	A	B	C	D	E	F	0005	0013	0102	1001	1100	
6	+	6	7	8	9	A	B	C	D	E	F	0006	0014	0103	0104	1002	1101	
7	BEL	7	8	9	A	B	C	D	E	F	0007	0015	0104	0105	1003	1102	1110	
8	BS	8	9	A	B	C	D	E	F	0008	0016	0105	0106	1004	1103	1111	1000	
9	CAN	9	A	B	C	D	E	F	0009	0017	0106	0107	1005	1104	1112	1001	1000	
A	HT	A	B	C	D	E	F	000A	0018	0107	0108	1006	1105	1113	1002	1001	1001	
B	LF	B	C	D	E	F	000B	0019	0108	0109	1007	1106	1114	1003	1002	1002	1010	
C	VT	C	D	E	F	000C	0020	0109	0110	1008	1107	1115	1004	1003	1003	1003	1011	
D	ESC	D	E	F	000D	0021	0110	0111	1009	1108	1116	1005	1004	1004	1004	1004	1012	
E	FF	E	F	000E	0022	0111	0112	1010	1109	1117	1006	1005	1005	1005	1005	1005	1013	
F	CR	F	000F	0023	0112	0113	1011	1110	1118	1007	1006	1006	1006	1006	1006	1006	1014	
0000	0001	0010	0011	0100	0101	0110	0111	1000	1001	1010	1011	1100	1101	1110	1111	1000	1001	

# Epson LQ Command Summary

You can use the control codes listed in the following tables when the printer is in LQ mode; that is, when DIP switch 11 is set to ON.

---



**NOTE:** Because of hardware differences, the justification code, ESC a, is not supported by your printer. Also, the styles of block graphics characters at 12 cpi are different from normal Epson LQ-510 printing.

---

## Basic Control Codes

<u>Function</u>	<u>ASCII</u>	<u>Decimal</u>	<u>Hexadecimal</u>
End command	NUL	0	00
Sound beeper	BEL	7	07
Backspace one character	BS	8	08
Horizontal tab control; move to next tab	HT	9	09
Perform line feed	LF	10	0A
Vertical tab control; move to next tab	VT	11	0B
Perform form feed	FF	12	0C
Perform carriage return	CR	13	0D
Set double-wide mode by line	SO	14	0E
Set condensed mode (17 cpi); cancelled by DC2	SI	15	0F
Set printer on-line	DC1	17	11
Cancel condensed mode (17 cpi) set by SI	DC2	18	12
Set printer off-line	DC3	19	13
Cancel double-wide mode	DC4	20	14

◀ BACK

NEXT ▶

▶ BACK TO START

<u>Function</u>	<u>ASCII</u>	<u>Decimal</u>	<u>Hexadecimal</u>
Cancel data	CAN	24	18
Start escape sequence	ESC	27	1B
Insert space	SP	32	20
Delete character	DEL	127	74

## ***ESCape Sequence Codes***

<u>Function</u>	<u>ASCII</u>	<u>Decimal</u>	<u>Hexadecimal</u>
Set double-wide mode by line	ESC SO	27 14	1B 0E
Set condensed mode	ESC SI	27 15	1B 0F
Control sheet feeder n Setting R Eject paper	ESC EM n	27 25 n	1B 19 n
Set intercharacter space	ESC SP n	27 32 n	1B 20 n
Set/cancel various print modes (Master Select)	ESC ! n	27 33 n	1B 21 n
Cancel most significant bit (MSB) control	ESC #	27 35	1B 23
Set absolute print position	ESC \$ n1 n2	27 36 n1 n2	1B 24 n1 n2
Select download character set n Setting 0 Use ROM character set 1 Use RAM character set	ESC % n	27 37 n	1B 25 n
Define downloaded characters	ESC &	27 38	1B 26
Select score mode	ESC ( - n1 n2 m d1 d2	27 40 45 n1 n2 m d1 d2	1B 28 2D n1 n2 m d1 d2
Select image graphics mode	ESC * m n1 n2	27 42 m n1 n2	1B 2A m n1 n2



<u>Function</u>	<u>ASCII</u>	<u>Decimal</u>	<u>Hexadecimal</u>
Set line spacing increments of n/360 per line; n = 0 to 255	ESC + n	27 43 n	1B 2B n
Set/cancel underscore mode n Setting mode 0 Start underscore 1 End underscore	ESC - n	27 45 n	1B 2D n
Select vertical tab channel; n = 0 to 7	ESC / n	27 47 n	1B 2F n
Set 1/8-inch line spacing (8 lpi)	ESC 0	27 48	1B 30
Set 1/6-inch line spacing (6 lpi)	ESC 2	27 50	1B 32
Set line spacing in n/180-inch increments; n = 1 to 255	ESC 3 n	27 51 n	1B 33 n
Set italic mode	ESC 4	27 52	1B 34
Cancel italic mode	ESC 5	27 53	1B 35
Enable printable range	ESC 6	27 54	1B 36
Cancel printable range expansion	ESC 7	27 55	1B 37
Copy ROM font to RAM	ESC :	27 58	1B 3A
Set unidirectional print by line	ESC	27 60	1B 3C
Set most significant bit (MSB) to 0	ESC =	27 61	1B 3D
Set most significant bit (MSB) to 1	ESC	27 62	1B 3E
Reassign image graphics mode	ESC ? n m	27 63 n m	1B 3F n m
Reset printer settings to the default values that were set when you turned on the printer	ESC @	27 64	1B 40

<u>Function</u>	<u>ASCII</u>	<u>Decimal</u>	<u>Hexadecimal</u>
Set n/60-inch line spacing; n = 0 to 127	ESC A n	27 65 n	1B 41 n
Set vertical tabs; n1, n2 = line numbers for tab stops	ESC B n1 n2	27 66 n1 n2	1B 42 n1 n2
Set page length in lines; n = 1 to 127	ESC C n	27 67 n	1B 43 n
Set page length in inches; n = 1 to 14	ESC C NUL n	27 67 0 n	1B 43 00 n
Set horizontal tabs; n1 ... n32 = columns for tab stops	ESC D n1 ... n32	27 68 n1 ... n32	1B 44 n1 ... n32
Set emphasized mode (printing in twice the normal dot density)	ESC E	27 69	1B 45
Cancel emphasized mode set by ESC E	ESC F	27 70	1B 46
Set double-strike mode	ESC G	27 71	1B 47
Cancel double-strike mode	ESC H	27 72	1B 48
Perform n/180-inch line feed; n = 0 to 255	ESC J n	27 74 n	1B 4A n
Set single-density graphics mode	ESC K n1 n2	27 75 n1 n2	1B 4B n1 n2
Set double-density graphics mode	ESC L n1 n2	27 76 n1 n2	1B 4C n1 n2
Set 12 cpi mode	ESC M	27 77	1B 4D
Set perforation skip; n = 1 to 127 lines	ESC N m	27 78 n	1B 4E n
Cancel perforation skip	ESC O	27 79	1B 4F
Set 10 cpi mode	ESC P n	27 80 n	1B 50 n
Set right margin	ESC Q n	27 81 n	1B 51 n
Select international character set	ESC R n	27 82 n	1B 52 n

<b><u>Function</u></b>	<b><u>ASCII</u></b>	<b><u>Decimal</u></b>	<b><u>Hexadecimal</u></b>
Set super/subscript mode n Setting 0 Select superscript mode 1 Select subscript mode	ESC S n	27 83 n	1B 53 n
Cancel super/subscript mode set by ESC S	ESC T	27 84	1B 54
Select print direction n Setting 0 Cancel unidirectional mode 1 Select unidirectional mode	ESC U n	27 85 n	1B 55 n
Set/cancel double-wide mode n Setting 0 Cancel double-wide mode 1 Start double-wide mode	ESC W n	27 87 n	1B 57 n
Set double-density graphics mode	ESC Y n1 n2	27 89 n1 n2	1B 59 n1 n2
Set quadruple density graphics mode	ESC Z n1 n2	27 90 n1 n2	1B 5A n1 n2
Set relative print position	ESC \ n1 n2	27 92 n1 n2	1B 5C n1 n2
Set vertical tabs in channels; n = 0 to 7	ESC b n	27 98 n	1B 62 n
Set 15 cpi mode; use ESC P to cancel	ESC g	27 103	1B 67
Select typeface	ESC k n	27 107 n	1B 6B n
Set left margin	ESC l n	27 108 n	1B 6C n
Set/cancel proportional space mode n Setting 0 Cancel PS mode 1 Start PS mode	ESC p n	27 112 n	1B 70 n
Select character style	ESC q n	27 113 n	1B 71 n

<u>Function</u>	<u>ASCII</u>	<u>Decimal</u>	<u>Hexadecimal</u>
Select character set n Setting	ESC t n	27 116 n	1B 74 n
0 Italics character set			
1 Graphics character set			
2 Remap download characters from 0-127 to 128-255			
Set/cancel double-high mode n Setting	ESC w n	27 119 n	1B 77 n
0 Cancel double-high mode			
1 Start double-high mode			
Set/cancel high quality mode n Setting	ESC x n	27 120 n	1B 78 n
0 Cancel high quality mode			
1 Start high quality mode			

## ***Epson LQ Character Sets***

In Epson LQ mode, your printer can access the following character sets:

- Epson Italics character sets
- Epson Graphics character set

The Italics character set has control codes in two places: between ASCII 0 and ASCII 32, and also between ASCII 128 and ASCII 159. In addition, the Italics character set has the italics characters between ASCII A0 and ASCII FF. All other characters are printable. The characters from ASCII 80 to ASCII FF correspond to IBM Character Set 2.

Use DIP switch 5 to select the Epson character set. Set DIP switch 5 ON to select the Graphics character set, or set it OFF to select the Italics character set.



To select an international character set, set DIP switches 6, 7, and 8, as follows:

<u>Country</u>	<u>DIP switches</u>		
	<b>6</b>	<b>7</b>	<b>8</b>
USA	OFF	OFF	OFF
United Kingdom	OFF	OFF	ON
Germany	OFF	ON	OFF
France	OFF	ON	ON
Denmark	ON	OFF	OFF
Sweden	ON	OFF	ON
Italy	ON	ON	OFF
Spain	ON	ON	ON

## Epson Italics Character Set

Hex Dec	D	1	2	3	4	5	6	7	8	9	A	B	C	E	F	
00	NUL	SP	!	@	P	~	p	NUL	SP	0	1	2	3	4	5	0000
01	DC1	!	A	Q	a	q		DC2	7	T	A	O	R	Q		0001
02	DC2	!	B	R	b	r		DC3	8	U	B	P	D	7		0010
03	DC3	!	C	S	c	s		DC4	9	V	C	E	F	8		0011
04	DC4	!	D	T	d	t		DC5	A	W	D	G	H	9		0100
05	%	E	U	e	u			%	B	X	L	I	J			0101
06	^	F	V	f	v			^	C	Y	M	N	O			0110
07	&	G	W	g	w			&	D	Z	W	X	Y			0111
08	BEL	^	H	X	h	x		BEL	E	[	G	V	Z			1000
09	BS	^	I	Y	i	y		BS	F	\	H	W	[			1001
0A	CAN	^	J	Z	j	z		CAN	G	]	I	X	]			1010
0B	EM	^	K	[	k	[		EM	H	^	J	Y	^			1011
0C	LF	^	L	]	l	]		LF	I	_	K	Z	_			1100
0D	VT	^	M	^	m	^		VT	J	`	L	[	`			1101
0E	ESC	^	N	^	n	^		ESC	K	~	M	]	~			1110
0F	SO	^	O	^	o	^		SO	L	`	N	^	`			1111
10	DEL	^	P	^	p	^		DEL	M	`	O	^	`			
11									N	`	P	^	`			
12									O	`	Q	^	`			
13									P	`	R	^	`			
14									Q	`	S	^	`			
15									R	`	T	^	`			
16									S	`	U	^	`			
17									T	`	V	^	`			
18									U	`	W	^	`			
19									V	`	X	^	`			
1A									W	`	Y	^	`			
1B									X	`	Z	^	`			
1C									Y	`	[	^	`			
1D									Z	`	]	^	`			
1E									[	`	^	`	`			
1F									]	`	^	`	`			
20									^	`	`	`	`			
21									`	`	`	`	`			
22									`	`	`	`	`			
23									`	`	`	`	`			
24									`	`	`	`	`			
25									`	`	`	`	`			
26									`	`	`	`	`			
27									`	`	`	`	`			
28									`	`	`	`	`			
29									`	`	`	`	`			
2A									`	`	`	`	`			
2B									`	`	`	`	`			
2C									`	`	`	`	`			
2D									`	`	`	`	`			
2E									`	`	`	`	`			
2F									`	`	`	`	`			
30									`	`	`	`	`			
31									`	`	`	`	`			
32									`	`	`	`	`			
33									`	`	`	`	`			
34									`	`	`	`	`			
35									`	`	`	`	`			
36									`	`	`	`	`			
37									`	`	`	`	`			
38									`	`	`	`	`			
39									`	`	`	`	`			
3A									`	`	`	`	`			
3B									`	`	`	`	`			
3C									`	`	`	`	`			
3D									`	`	`	`	`			
3E									`	`	`	`	`			
3F									`	`	`	`	`			
40									`	`	`	`	`			
41									`	`	`	`	`			
42									`	`	`	`	`			
43									`	`	`	`	`			
44									`	`	`	`	`			
45									`	`	`	`	`			
46									`	`	`	`	`			
47									`	`	`	`	`			
48									`	`	`	`	`			
49									`	`	`	`	`			
4A									`	`	`	`	`			
4B									`	`	`	`	`			
4C									`	`	`	`	`			
4D									`	`	`	`	`			
4E									`	`	`	`	`			
4F									`	`	`	`	`			
50									`	`	`	`	`			
51									`	`	`	`	`			
52									`	`	`	`	`			
53									`	`	`	`	`			
54									`	`	`	`	`			
55									`	`	`	`	`			
56									`	`	`	`	`			
57									`	`	`	`	`			
58									`	`	`	`	`			
59									`	`	`	`	`			
5A									`	`	`	`	`			
5B									`	`	`	`	`			
5C									`	`	`	`	`			
5D									`	`	`	`	`			
5E									`	`	`	`	`			
5F									`	`	`	`	`			



**NOTE:** The characters in the shaded areas in the preceding table change according to the selected international character set.

## Epson Graphics Character Set

Hex No.	0	1	2	3	4	5	6	7	8	9	A	B	C	D	E	F	Hex No.
0	ROL	SP	U	Q	P	Q	Q	Q	Q	Q	Q	Q	Q	Q	Q	Q	0000
1	CC1	T	T	A	O	R	Q	Q	Q	Q	Q	Q	Q	Q	Q	Q	0001
2	CC2	U	U	B	R	D	F	Q	Q	Q	Q	Q	Q	Q	Q	Q	0010
3	CC3	S	S	D	S	Q	Q	Q	Q	Q	Q	Q	Q	Q	Q	Q	0011
4	CC4	A	A	D	Y	d	t	A	G	N	-	-	-	-	-	-	0100
5	CC5	W	W	W	W	W	W	W	W	W	W	W	W	W	W	W	0101
6	CC6	A	O	P	V	t	v	A	G	B	-	-	-	-	-	-	0110
7	BEL	Y	Q	W	Q	W	Q	W	Q	W	Q	W	Q	W	Q	W	0111
8	BS	CAN	(	B	H	X	H	X	G	V	L	-	-	-	-	-	1000
9	HT	EM	)	D	I	Y	i	Y	Q	Q	Q	Q	Q	Q	Q	Q	1001
A	LF	Q	J	Z	I	A	Q	Q	Q	Q	Q	Q	Q	Q	Q	Q	1010
B	VT	ESC	Q	K	L	K	L	K	L	K	L	K	L	K	L	K	1011
C	FF	Q	L	L	L	L	L	L	L	L	L	L	L	L	L	L	1100
D	CR	Q	M	J	K	J	K	J	K	J	K	J	K	J	K	J	1101
E	SO	Q	N	^	1	-	A	Q	Q	Q	Q	Q	Q	Q	Q	Q	1110
F	SI	Q	O	-	Q	DEL	A	Q	Q	Q	Q	Q	Q	Q	Q	Q	1111
																	Binary File



**NOTE:** The characters in the shaded areas in the table above change according to the selected international character set.

# International Character Set

Use the table below to determine what characters appear in the shaded areas of the Epson character sets.

	Hex Dec	23	24	40	5B	5C	5D	5E	6D	7B	7C	7D	A3	A4	C3	D3	DC	DD	DE	E3	F3	FD	FE
0	U.S.A.	␣	␣	␣	␣	␣	␣	␣	␣	␣	␣	␣	␣	␣	␣	␣	␣	␣	␣	␣	␣	␣	␣
1	France	␣	␣	␣	␣	␣	␣	␣	␣	␣	␣	␣	␣	␣	␣	␣	␣	␣	␣	␣	␣	␣	␣
2	Germany	␣	␣	␣	␣	␣	␣	␣	␣	␣	␣	␣	␣	␣	␣	␣	␣	␣	␣	␣	␣	␣	␣
3	E.K.	␣	␣	␣	␣	␣	␣	␣	␣	␣	␣	␣	␣	␣	␣	␣	␣	␣	␣	␣	␣	␣	␣
4	Denmark I	␣	␣	␣	␣	␣	␣	␣	␣	␣	␣	␣	␣	␣	␣	␣	␣	␣	␣	␣	␣	␣	␣
5	Sweden	␣	␣	␣	␣	␣	␣	␣	␣	␣	␣	␣	␣	␣	␣	␣	␣	␣	␣	␣	␣	␣	␣
6	Italy	␣	␣	␣	␣	␣	␣	␣	␣	␣	␣	␣	␣	␣	␣	␣	␣	␣	␣	␣	␣	␣	␣
7	Spain I	␣	␣	␣	␣	␣	␣	␣	␣	␣	␣	␣	␣	␣	␣	␣	␣	␣	␣	␣	␣	␣	␣
8	Japan	␣	␣	␣	␣	␣	␣	␣	␣	␣	␣	␣	␣	␣	␣	␣	␣	␣	␣	␣	␣	␣	␣
9	Norway	␣	␣	␣	␣	␣	␣	␣	␣	␣	␣	␣	␣	␣	␣	␣	␣	␣	␣	␣	␣	␣	␣
10	Norway II	␣	␣	␣	␣	␣	␣	␣	␣	␣	␣	␣	␣	␣	␣	␣	␣	␣	␣	␣	␣	␣	␣
11	Spain II	␣	␣	␣	␣	␣	␣	␣	␣	␣	␣	␣	␣	␣	␣	␣	␣	␣	␣	␣	␣	␣	␣
12	Latin America	␣	␣	␣	␣	␣	␣	␣	␣	␣	␣	␣	␣	␣	␣	␣	␣	␣	␣	␣	␣	␣	␣
13	Greek	␣	␣	␣	␣	␣	␣	␣	␣	␣	␣	␣	␣	␣	␣	␣	␣	␣	␣	␣	␣	␣	␣
64	Legal	␣	␣	␣	␣	␣	␣	␣	␣	␣	␣	␣	␣	␣	␣	␣	␣	␣	␣	␣	␣	␣	␣

◀ BACK      ▶ BACK TO START